

ELR-3E1

Earth Leakage Relay DIN rail mounting version



GENERAL

The ELR-3E, maintain all the basic characteristics of other ELR series, although its reduced dimensions. It comes to complete the range of relays, built in a modular enclosure, according with DIN 43880 Standard, with a three modules width (module base 17.5 mm)

It has a wide setting ranges and the accurate tripping current selection (by means of dipswitches), in order that the contact voltage values are maintained below 50V as required by the CEI 64-8 Standard

This is also the idoneous answer for a proper selectivity, whenever there are other ELR's or/and RCD's downstream or upstream in the line to be protected.

An outstanding characteristic of the present relays, is the permanent control of the Toroidal - ELR circuit.

Its interruption brings along the immediate trip of the protection. This allows to identify the anomaly, without waiting to the periodical control, made with the Test push button. The instrument, fitted with filters at the input circuits, is practically immune to external disturbances, so as the pulse currents with dc components, complying with the requirements of VDE 0664 and project IEC 23 Standards.

The ELR-3E has a manual reset option only, in order to avoid unexpected reset, whilst undergoing repairs and maintenance works.

Its sealable front transparent cover may be used to avoid access to the settings to unauthorised persons.

It may also be coupled to any of our CT-1 Toroidal Transformers.

MODELS

ELR-3E1 = 0.03 ÷ 1 A setting

Option :
T = tropicalisation

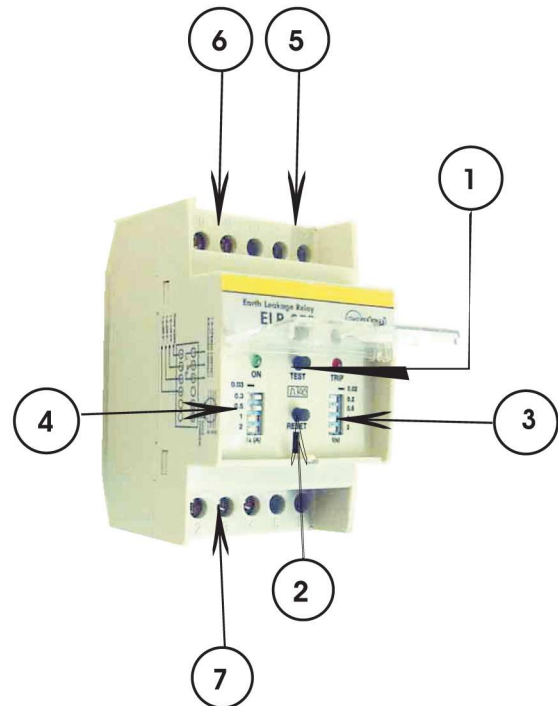

DESCRIPTION

- 1.-Test push button
- 2.-Reset push button
- 3.-Dipswitches for tripping time setting.
- 4.-Dipswitches for current tripping setting
- 5.-Terminals for the CT-1 toroidal connection.
- 6.-Relay's output terminals
- 7.-Auxiliary supply input terminals

Earth Leakage Relay — ELR-3E

ELECTRICAL CHARACTERISTICS

Auxiliary Voltage supply	110 Vac/dc 230 - 400 Vac \pm 20%
Frequency	50-60Hz
Maximum consumption	3 VA
Output: 1 changeover contact	5A 250V
Working Temperature	-10 + 60°C
Storing Temperature	-20 + 80°C
Humedad relativa	<90%
Insulation Test	2,5 kV 60 sec.
Standards	CEI 41-1 - IEC 255 - VDE 0664
Electromagnetic Compatibility	CEI-EN 50081-1 CEI-EN 50082-2
Wiring method	Terminals for cross section cable of 2,5 mm ²
Mounting according DIN 50022	Quick mountin on a DIN rail of 35 mm
Protection degree according DIN 40050	Ip20

WIRING DIAGRAM

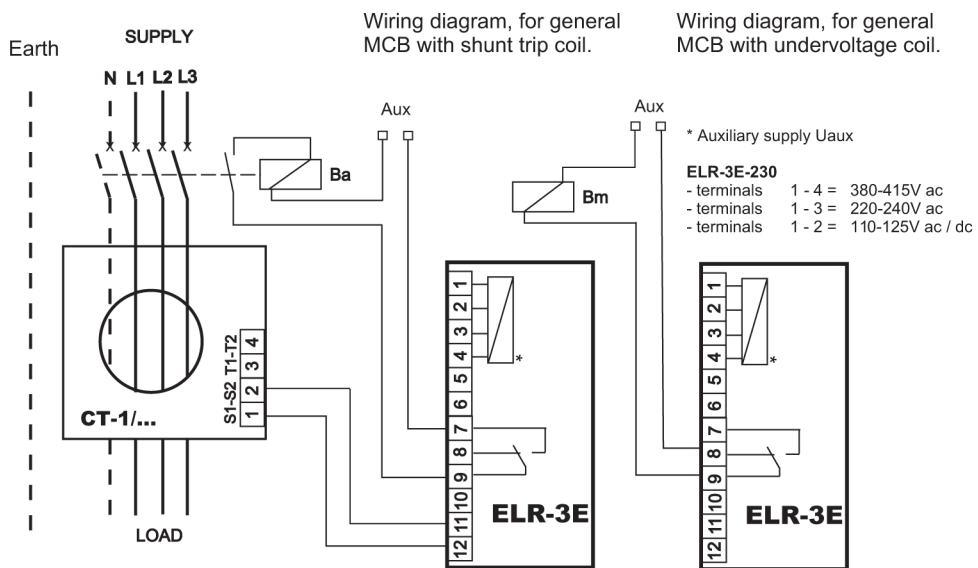

The output contact can be used also for tripped relay signalling only, without connecting the output to the tripping coil.

SETTING for current and tripping time

ELR-3E1

