

ELR-3C *Earth Leakage Relay*

DIN rail mounting version



MODELS

ELR-3C = 110Vac/dc - 230 - 400 Vca

ELR-3C = 24 - 48 Vac/dc

ELR-3C = 12 Vac/dc

Option :

T = tropicalization

GENERAL

The ELR-3C, maintain all the basic characteristics of the DIN 96x96 mm series, although its reduced dimensions. It is one of the relays series, built in a modular enclosure, according with DIN 43880 Standard, with a three modules width (module base 17.5 mm)

Its wide setting ranges allows to select the tripping current, in order that the contact voltage values are maintained below 50V as required by the CEI 64-8Standard.

This is also the suitable answer for a proper selectivity, whenever there are other ELR's or/and RCD's downstream or upstream in the line to be protected.

An outstanding characteristic of the present relays, is the permanent control of the Toroidal - ELR circuit.

Its interruption brings along the immediate trip of the protection. This allows to identify the anomaly, without waiting to the periodical control, made with the Test push button.

The instrument, fitted with filters at the input circuits, is practically immune to external disturbances, so as the pulse currents with dc components, complying with the requirements of VDE 0664 and project IEC 23 Standards.

The ELR-3C has the possibility of an automatic or manual reset, selectable by a micro switch and to protect the settings by its sealable transparent front cover.

This relay accepts also the possibility of a remote test.

It may also be coupled to any of our CT-1 Toroidal Transformers.

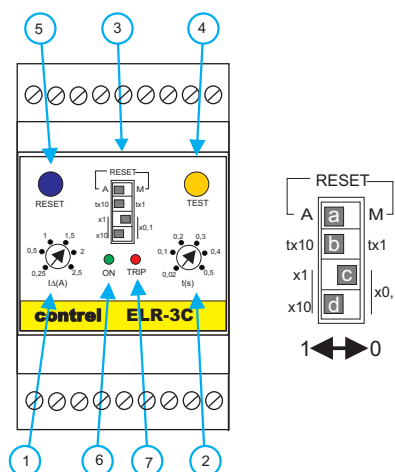

DESCRIPTION

- 1) Current tripping setting potentiometer.
- 2) Tripping time setting potentiometer.
- 3) Micro switches for programming:
 - a In position 1 automatic reset,
In position 0 manual reset
 - b Selection of the multiplying constant
Tripping time, in position 1 K=10
in position 0 K=1
 - c, d Selection of the multiplying constant of
tripping current:
With c, d in position 0 K=0.1
With c in position 1, d in position 0 K=1.
With c, d in position 1 K=10
- 4) Push button for Test
- 5) Push button for manual reset
- 6) Signalling green LED for Aux. Supply presence
- 7) Signalling red LED for relay tripped

ELR-3C Earth Leakage Relay

ELECTRICAL CHARACTERISTICS

Auxiliary Voltage supply	12Vac/dc 24+48 Vac/dc 110 Vac/dc 230 - 400 Vac \pm 20%
Frequency	50-60Hz
Maximum consumption	3 VA
Current tripping adjustment range $I_{\Delta N}$	0,025+0,25A K=0,1 - 0,25+2,5A K=1 - 2,5+25A K=10 25+250A*
Tripping time adjustment range t	0,02 + 0,5 sec. K=1 - 0,2 + 5 sec. K=10
Output: 1 changeover contact	5A 250V
Working Temperature	-10 + 60°C
Storing Temperature	-20 + 80°C
Relative humidity	<90%
Insulation Test	2,5 kV 60 seg.
Standards	CEI 41-1/IEC 255/VDE 0664/IEC 755/CEI 64.8/ EN 61008-1(1999-11)/EN 62020 (1999-09) / EN 61543 (1996-09) /EN61326-1(1998-04) / EN 61326/A1 (1999-05)
Wiring method	Screw terminals for cross section wires 2,5 mm ²
Mounting according DIN 50022	Snap on DIN rail 35 mm
Protection degree according DIN 40050	Ip20

* By means of external multiplier

WIRING DIAGRAM

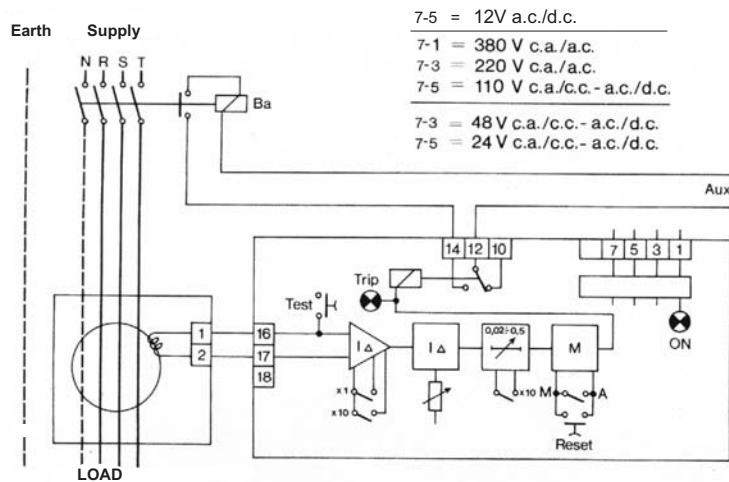

DIMENSIONS

