

AC-DC sensitive residual current devices (Type B RCDs)



Instructions for use and technical information



Liability

All information contained in this document belonging to Doepke Schaltgeräte GmbH is protected by copyright. The reproduction and processing, altering and/or transfer against payment of such information is permissible only with the express written approval of Doepke Schaltgeräte GmbH. This information is provided solely as customer information and does not constitute a binding guarantee or undertaking. It is subject to changes at any time, whether in terms of technical content or in price/commercial. Binding statements can only be given following specific enquiries. The use of this document is solely at your own discretion. Doepke Schaltgeräte GmbH accepts no liability for any damages arising from the use of this document, in particular breakdown of operations, loss of earnings, loss of information and data or consequential damages, except in cases of compulsory liability, e.g. as provided for by the Product Liability Law, or in cases of premeditation, gross negligence, absence of promised capabilities or because of infringement of fundamental contractual obligations. Compensation for infringement of fundamental contract obligations shall, however, be limited to contract-typical foreseeable damage, provided there is no premeditation or gross negligence.

Technical Information

February 2017

Part I Why "AC-DC sensitive"?

1.	Why "AC-DC sensitive"?	8
1.1	AC-DC sensitive residual current operated protective devices (Type B RCDs) in electrical systems with frequency converters	8
1.2	What are residual currents and what are leakage currents?	9
1.2.1	Residual currents	9
1.2.2	Leakage currents	9
1.3	Which residual currents may occur in electrical systems with frequency converters?	10
1.3.1	Insulation fault at the frequency converter input	10
1.3.2	Insulation fault at the intermediate circuit capacitor of the frequency converter	11
1.3.3	Fault between the frequency converter and the motor	11
1.3.4	Single-phase operated frequency converter	12
1.4	General observation on leakage currents	13
1.4.1	Stationary leakage currents	14
1.4.2	Note on the use of single-phase operated frequency converters	15
1.4.3	Variable leakage currents	15
1.4.4	Transient leakage currents	16
1.5	Measures to reduce leakage currents	17
1.5.1	Reduction of stationary leakage currents	18
1.5.2	Reduction of variable leakage currents	19
1.5.3	Additional possibilities for reducing stationary and variable leakage currents	19
1.5.4	Reduction of transient leakage currents when switching an electrical system with electronic equipment on and off	20
1.5.5	Avoiding natural oscillation (resonance) by an EMC filter	21
1.5.6	Inductive leakage currents	22
1.5.7	Changes to existing electrical systems	22
1.6	Important information concerning the use of frequency converters with integrated EMC filters	23
1.7	Measurement of leakage currents	23
1.8	Correct use of an AC-DC sensitive residual current circuit-breaker in an electrical system with electronic equipment	25
1.8.1	Regulatory-compliant use of AC-DC sensitive residual current operated protective devices	25
1.8.2	Protective measures when operating frequency-controlled equipment on construction sites	26
1.8.3	Use of RCDs in electrical systems with a PV power supply system	29

1.0.1	Use of RCDs in electric machines.....	31
1.8.4	Additional uses for AC-DC sensitive residual current operated protective devices	32
1.8.6	Additional guidelines requiring Type B RCDs:	34
1.9	Division of electric circuits	34
1.10	RCDs as protection via automatic power supply switch-off in the event of a fault	35
1.11	Basic circuits for electronic equipment and the potential residual currents which may result	36

Part II The frequency response of the tripping current of AC-DC sensitive RCDs and its significance for the level of protection

2.	The frequency response of the tripping current of AC-DC sensitive RCDs and its significance for the level of protection	42
1.1	Protection from Type A RCDs which are sensitive to pulsating currents	42
1.2	Protection from Type F RCDs	43
1.3	Protection when charging electric vehicles using DFS 4 A EV.....	43
1.4	Protection when using AC-DC sensitive residual current circuit-breakers (MI design)	44
1.5	The frequency response of the tripping current for AC-DC sensitive RCDs and its significance for the level of protection.....	45
1.6	Protection from Type B RCDs with extended frequency range for the response current (AC-DC sensitive RCDs).....	46
1.7	Requirements applicable to the magnitude of the tripping current on the basis of frequency	47
1.8	Requirements applicable to the upper frequency limit of residual current detection	50
1.9	Frequency response for a consistent level of protection against low or medium leakage currents	52
1.10	Frequency response with a "change in protection level" in systems with high leakage currents	53
1.11	Requirements laid down in standards in relation to the tripping current frequency response	55
1.12	Earth resistances for fault protection.....	56
1.13	Summary	56

Part III Appendix

3.	Appendix.....	60
3.1	Abbreviations used in the text.....	60
3.2	Overview tables for RCDs of Type B SK /B+ /NK.....	61
3.3	Index.....	63

Part I

Why "AC-DC sensitive"?

1. Why "AC-DC sensitive"?

1.1 AC-DC sensitive residual current operated protective devices (Type B RCDs) in electrical systems with frequency converters

Multi-phase operated electronic equipment such as e.g. frequency converters (FC) or inverters may produce a smooth DC residual current in the event of a fault, as shown in Fig. 1.

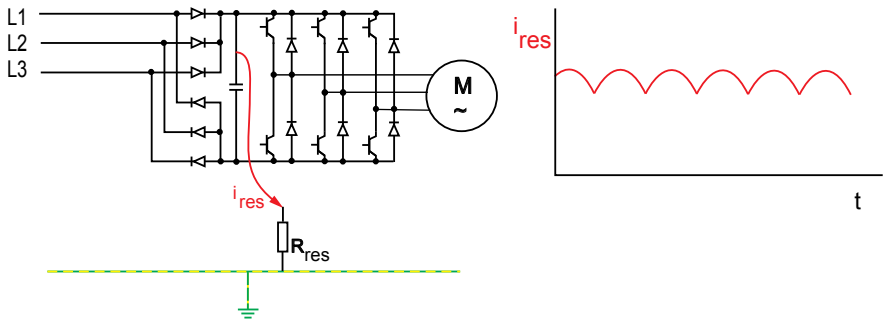

Fig. 1: Production of an almost smooth DC residual current (simplified representation of a frequency converter with B6 bridge rectifier, intermediate circuit capacitor, output level and motor)

The smooth DC residual current produced by B6 switching at the frequency converter input¹ would not cause tripping by traditional RCDs (*residual current operated protective devices*) of Type A or AC owing to the absence of the time-varying magnetization in the summation current transformer required for inductive energy transfer to the trip relay. Depending on its magnitude, the DC residual current instead results in the pre-magnetisation of the transformer core, thus increasing the tripping threshold for additional DC residual currents which may also be present and potentially preventing tripping.

¹ Formation of the DC residual current from the three individual currents of the line conductors L1, L2 and L3 is shown in greater detail in Fig. 5 (p. 11).

1.1 What are residual currents and what are leakage currents?

1.1.1 Residual currents

Residual currents are predominantly resistive and are created by insulation faults between voltage-carrying parts and earth, for example as a result of dirt and moisture in a device. Another example would be the flow of current to earth which occurs when an individual comes into direct contact with an active conductor in the network (see Fig. 2).

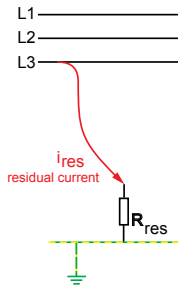

Fig. 2: AC residual current

1.1.1 Leakage currents

Leakage currents are usually capacitive currents which occur under operating conditions and which flow e.g. as a result of anti-interference measures through capacitors in EMC filters or via the capacitance of long shielded cables to earth (see Fig. 3).

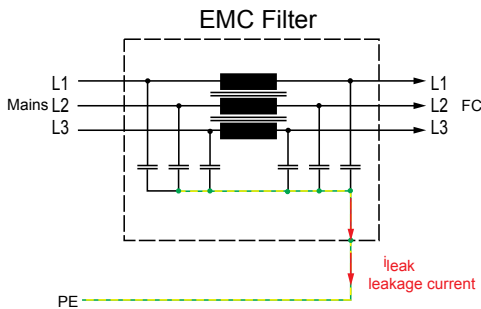

Fig. 3: capacitive leakage current (simplified representation of an EMC filter)

Both residual currents and leakage currents can be simultaneously composed of several frequency components which differ significantly from the mains frequency of 50 Hz, depending on the application and the electrical system. RCDs cannot distinguish between residual currents and leakage currents, which are therefore evaluated identically. For example, tripping may take place if the sum of all the leakage currents flowing exceeds the tripping threshold for the residual current operated protective device, even though there is no fault (residual current) in the electrical system.

1.2 Which residual currents may occur in electrical systems with frequency converters?

1.1.2 Insulation fault at the frequency converter input

An earth fault is present at the frequency converter input. A purely sinusoidal residual current of 50 Hz is flowing. If this residual current is high enough, the residual current operated protective device will be reliably tripped.

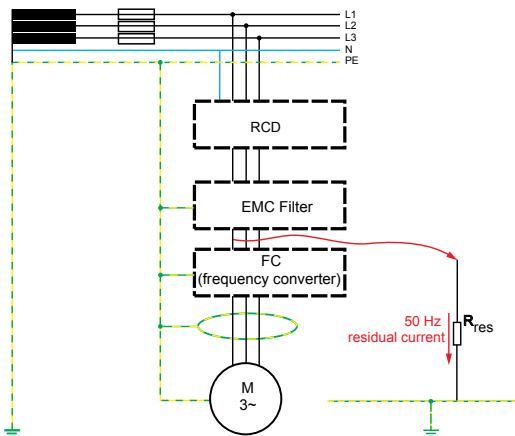
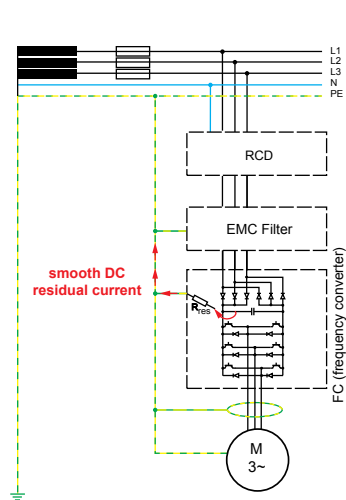

Fig. 4: Residual current of 50 Hz

1.2.1 Insulation fault at the intermediate circuit capacitor of the frequency converter

An insulation fault occurs between the positive terminal of the intermediate circuit capacitor to the frequency converter housing. This fault may be caused, for example, by dirt and exposure to moisture. An almost smooth DC residual current is flowing. If Type B RCDs are used, reliable tripping is guaranteed if the DC residual current is high enough.



Note: In many frequency converters, the two poles of the intermediate circuit (DC+, DC-) are routed to the exterior in the form of two terminals e.g. for energy recovery. They are therefore particularly vulnerable to dirt and/or moisture.

Fig. 5: DC residual current

1.2.2 Fault between the frequency converter and the motor

The motor is operated at an output frequency (also referred to as machine or motor frequency) of 10 Hz. The switching frequency (also referred to as chopper or elementary frequency) of the frequency converter is 8 kHz. A residual current is now flowing, made up of a very high number of frequency components. In addition to the output frequency of 10 Hz with a lower amplitude, the switching frequency of the frequency converter at 8 kHz and its harmonic components of 16 kHz, 24 kHz, 32 kHz etc. are also present as significant components. A 150 Hz component with low amplitude, generated by the input-side six-pulse bridge rectifier of the frequency converter, is also present.

Correct tripping is generally also guaranteed in this case when using Type B RCDs. In exceptional cases (depending on the EMC filter measures used), the higher-frequency components in the residual current may flow back predominantly via the filter capacities rather than exclusively via the star point, meaning that they are not fully detected by the residual current operated protective device. If necessary, a fault should be simulated using a suitable test device in order to determine whether correct tripping is guaranteed.

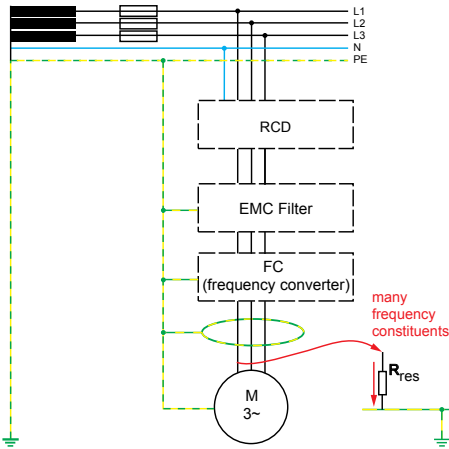

Fig. 6: Residual current with frequency mix

Note:

Alternatively, a Type B+ residual current operated protective device can also be used for the faults cited as examples in Section 1.3.

1.2.3 Single-phase operated frequency converter

If single-phase operated frequency converters are used in an electrical system, a Type F residual current operated protective device is generally sufficient. In the event of a fault, either a sinusoidal AC residual current or a pulsating DC residual current resulting from the rated frequency (50 Hz) occurs depending

on the fault point. Additional spectral components of the output frequency and the switching frequency with harmonic components are generally present in the residual current. Smooth DC residual currents cannot generally occur.

Specially designed single-phase operated frequency converters however contain a PFC stage or a boost converter in the intermediate circuit in order to raise the intermediate circuit voltage so that electric motors designed for a rated voltage of 400 V can also be connected. If frequency converters of this type are used, however, residual currents may occur in the event of a fault which have a high smooth DC content and will no longer be detected by Type A or F RCDs. Only Type B or B+ RCDs may be used in this case. The manufacturer of the frequency converter is obliged to provide information on this topic in the relevant documentation.

For further information, see the table with basic wiring diagram g in the section entitled "Basic circuits for electronic equipment and the potential residual currents which may result".

1.3 General observation on leakage currents

A distinction is made between stationary, variable and transient leakage currents. The example of a system with an asynchronous motor which is operated with a frequency converter will be used again for clarification purposes.

In order to comply with the relevant EMC regulations (*EMC: electromagnetic compatibility*), the frequency converter may only be operated using an upstream EMC filter, which may also be integrated into the frequency converter. Since the pulse-width modulated output voltage of the frequency converter has a very steep edge and therefore contains harmonic components of high amplitudes and frequencies, the motor (again, in order to comply with EMC regulations) may only be connected to the frequency converter using a shielded cable.

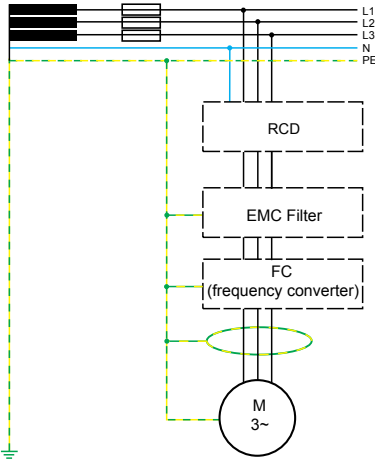

Fig. 7: Connection example with an asynchronous motor

1.3.1 Stationary leakage currents

In its simplest design, the EMC filter consists of LC low-pass filters with capacitors connected in the star to the protective conductor. In an ideal network with a strictly sinusoidal voltage, the sum of all capacitive currents through these capacitors is zero. As a result of the relatively strong distortions in the mains voltage, however, in practice there is a capacitive total current which is not equivalent to zero, which continuously flows via the protective conductor and which is therefore referred to as a stationary leakage current. Significant leakage currents are also generated through the commutation of the B6 bridge connection at the frequency converter input and of the internal Y capacitors from the intermediate circuit to the PE. If three-phase operated frequency converters are used, a 150 Hz component which depends on the size of the Y capacitors is mainly present. The 150 Hz leakage current generated in this way *cannot* generally be reduced, even by additional filter measures. When using RCDs with $I_{\Delta n} = 30 \text{ mA}$, this leakage current can therefore result in a high preload. Some frequency converter manufacturers indicate that the operation of frequency converters of this kind with an upstream residual current operated protective device may result in undesired tripping.

The stationary leakage current is also present if the motor is not running (controller lock of the frequency converter) and typically has frequency components of 100 Hz to 1 kHz and frequency components in the range of the resonance frequency of the EMC filter (typically in the range from 2 to 4 kHz). Particularly simple and cheap EMC filters with small inductances and large capacitors give rise to high leakage currents and can result in the undesired tripping of the residual current operated protective device.

1.3.2 Note on the use of single-phase operated frequency converters

Single-phase operated frequency converters are often fitted with an integrated EMC filter. The filter capacitors in this filter are connected from L to PE and N to PE. This results in significant 50 Hz leakage currents. If several frequency converters are used, care must be taken to ensure that they are distributed as uniformly as possible across the three line conductors L₁, L₂ and L₃ in order to compensate for the leakage currents and avoid tripping by the residual current operated protective device.

1.3.3 Variable leakage currents

If the speed of the motor is regulated by the frequency converter, additional frequency components will occur above 1 kHz in the total leakage current. In particular, the switching frequency of the frequency converter (typical values: 2, 4, 8, 16 kHz) and the associated harmonic components are present at a very high amplitude. A long motor cable with an earthed shielding has the same effect as a capacitor which is connected to earth and conducts currents at a corresponding frequency to earth together with their harmonic components. In addition, the frequency components in the range of the resonance frequency of the EMC filter can increase sharply if the switching frequency of the frequency converter is approximately the same as or a multiple of the resonance frequency of the EMC filter. The EMC filter is stimulated to oscillation by the switching frequency of the frequency converter and can generate very high leakage currents in the range of the resonance frequency. Even if the frequency converter is set to a very high switching frequency (e.g. 16 kHz),

at low output frequencies (including when the motor is started up and shut down) the frequency converter may significantly reduce its switching frequency automatically in line with the modified modulation method. In a worst-case scenario, the reduced switching frequency may be approximately the same as or a multiple of the resonance frequency of the EMC filter, meaning that the leakage current increases sharply and the risk of undesired tripping of a residual current operated protective device is therefore much greater. If the motor speed is constant, stationary and variable leakage currents are almost periodic. RCDs respond to these leakage currents by means of a switch-off if their height exceeds the response threshold for the residual current operated protective device at the relevant frequency. Changes in speed also bring about changes to the variable leakage currents in terms of both frequency spectrum and amplitude, and may potentially result in tripping.

1.3.4 Transient leakage currents

In the event of a switch-off, voltage peaks occur in the network due to inductances in the current paths, and contain very high frequency components due to the steep rising edges. In the event of a switch-on at an unfavourable mains voltage phase angle, the mains voltage spectrum also contains high-frequency components for short periods owing to the rapid rise in voltage. These high-frequency voltage components divert transient currents which may result in undesired RCD switch-offs to earth via the above-mentioned capacities of the EMC protective measures. If the mains voltage is switched on using switches without a snap-action function, the three line conductors will be connected to each other at staggered intervals depending on the switching speed. If voltage is not being carried by all of the conductors, an increased leakage current will flow to earth via the filter capacitors of the EMC filter from the conductors which have already been connected. Nuisance tripping due to transient leakage currents



Note: The filters described in this section are generally available as accessories from the manufacturers of the electronic equipment (frequency converters, inverters etc.). These manufacturers will also be able to provide further technical details if necessary.

can in many cases be avoided by using RCDs with response delay. In order to avoid any inadmissible impairment of the protective function, the response delay may not exceed certain maximum values. This means that RCDs cannot be 'immunised' on an arbitrary basis against transient leakage currents either. The RCDs of the DFS 4 B and DFL 8 B series have a response delay of this kind. If the duration of the transient leakage currents exceeds the maximum permissible response delay prescribed in the regulations, however, tripping will nevertheless occur at a corresponding value.

1.4 Measures to reduce leakage currents

As made clear in the above chapters, in most cases an improvement in the rate of nuisance tripping by RCDs as a result of leakage currents has an adverse impact on protective function. Use of the following measures to keep leakage currents as small as possible is therefore always to be recommended.

In line with paragraph 531.3.2 of HD 60364-5-53:2015 (Selection and erection of electric equipment), the electrical system must be designed in such a way that the leakage current does not exceed 0.3 times the rated residual current of the residual current operated protective device.

Filter measures (both internal filter components and filters installed before or after the frequency converter) significantly influence the flow of leakage currents and residual currents in an electrical system. Depending on the design of the filter measures, higher-frequency currents can flow through the Y capacitors in such a way that they can no longer be detected by upstream RCDs (which is undoubtedly beneficial in the case of undesired leakage currents). In order to ensure that higher-frequency residual currents (e.g. at the switching frequency of the frequency converter) are still detected by an upstream residual current operated protective device, attempts should be carried out where necessary with artificially generated faults (e.g. using suitable test devices) on the output side of the frequency converter in order to guarantee tripping in the event of a fault.

1.4.1 Reduction of stationary leakage currents

- » Many frequency converter manufacturers now offer 'low leakage current' EMC filters. The design of these types of filter means that the leakage currents are significantly lower than in standard filters. The manufacturer's specifications concerning the maximum permitted length of the shielded motor supply cable should be observed. The EMC filter E6 series from the manufacturer 'KEB Antriebstechnik' is a good example of this type of device. The filters in the E6 series only generate very low leakage currents and generally allow the use of Type B or B+ RCDs with a rated residual current of 30 mA.
- » A four-wire filter can be used in electric networks in which a neutral conductor is present. This filter type offers the lowest leakage currents: The main component of the leakage currents is discharged via the neutral conductor.
- » Additional measures should be taken to ensure that the mains voltage remains as undistorted as possible.
- » A single-phase consumer such as a single-phase operated frequency converter should not under any circumstances be connected to the neutral conductor at the output of a three-phase EMC filter (without neutral conductor connection). The asymmetric loading of the filter further increases the leakage currents, greatly impairing the filter effect and meaning that the permitted limits for compliance with the EMC regulations are exceeded by far.
- » If several single-phase operated frequency converters are used, they should be distributed uniformly across all line conductors in order to compensate for the leakage currents.



Note: Some dynamic drives prohibit or restrict the use of output filters. The manufacturer's recommendations should be followed.

1.4.2 Reduction of variable leakage currents

- » The shielded motor supply cable should be kept as short as possible. The motor supply cable should have a symmetric and low-impedance arrangement of internal conductors.
- » Sinusoidal filters, EMC sinus filters, du/dt filters or output chokes should be installed directly behind the output of the frequency converter (in front of the motor supply cable). By lowering the leading edge of the output voltage of the frequency converter, they significantly reduce leakage currents above 1 kHz on the cable to the motor. Particularly low leakage currents are achieved when using a du/dt filter.
- » By minimising the leading edge of the output voltage, output filters also reduce noise emissions as well as motor bearing currents and high inductance voltages at the motor coils.
- » If several frequency converters with their own (integrated) EMC filter are used, an additional upstream shared four-wire filter can be used to significantly reduce the variable leakage currents.

1.4.3 Additional possibilities for reducing stationary and variable leakage currents

- » Mains chokes which are placed upstream of the EMC filter reduce the current ripple and the associated harmonic components, and also increase the lifetime of components in the frequency converter.
- » In electrical systems with several frequency converters, a collective filter should be used instead of individual EMC filters for each frequency converter. The leakage currents of the individual EMC filters are added together. The sum of the leakage currents from all the individual filters is generally larger than the leakage current from a larger shared filter. The information provided by the filter manufacturer concerning the maximum permitted lengths of shielded motor supply cables should be observed.

- » If several frequency converters are used in an electrical system, care should be taken to avoid starting them up at the same time. Simultaneous controller releases for several frequency converters may temporarily result in high leakage currents which are added together, potentially resulting in undesired tripping.

1.4.4 Reduction of transient leakage currents when switching an electrical system with electronic equipment on and off

As mentioned above, compliance with the EMC regulations means that filters must be used if electronic equipment is installed. These filters contain, for example, a star connection of three capacitors to earth for a three-wire standard EMC filter. Most RCDs contain a simple sequential circuit. The closing and opening of the individual current paths over time depends on the switching speed of the contacts in the device and can result in a time difference of 10–40 ms under certain circumstances. The star point of the three capacitors is no longer balanced during this time. A significant capacitive leakage current may flow via the protective conductor, causing the residual current operated protective device to trip immediately. Connection and disconnection should therefore only take place using an additional fast-acting switching device (e.g. a disconnector with snap action function or an all-pole switching contactor) rather than the residual current operated protective device itself. In electrical

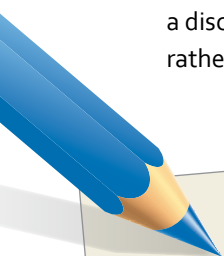

Example: The resonance frequency of the EMC filter is 2.1 kHz. If a switching frequency of 2 kHz were chosen for the frequency converter, it would be in the immediate vicinity of the resonance frequency and may result in very high leakage currents under certain circumstances. Even a switching frequency of 4 kHz may still lead to high leakage currents, since it corresponds to almost twice the resonance frequency. Higher switching frequencies and in particular non-multiples of the resonance frequency (e.g. 6 kHz, or preferably 7 kHz) reduce the risk that the EMC filter will suffer from a tendency to oscillation, along with the associated high leakage currents. Further details regarding the resonance frequency of the EMC filter and the potential deactivation of automatic changes to the switching frequency of a frequency converter at low output frequencies should be requested from the manufacturers of the equipment where necessary.

systems with a very large number of frequency converters, tripping may occur in exceptional cases, even where a fast-acting switching device is used, particularly during switch-on. In such cases, very high leakage currents flow for a period which exceeds the maximum permissible switch-off time as a result of the uncharged filter capacitors. A collective EMC filter for several frequency converters may also significantly reduce the high switch-on leakage current.

1.4.5 Avoiding natural oscillation (resonance) by an EMC filter

As a rule, different switching frequencies (chopper) can be selected in the case of electronic equipment such as frequency converters. In a worst-case scenario (e.g. a long shielded motor supply cable), the switching frequency may result in the oscillation of an upstream EMC filter and greatly increased leakage currents as a consequence, which then lead to tripping of the residual current operated protective device. The switching frequency of the frequency converter must be changed in such cases. In addition, the maximum permitted length prescribed by the frequency converter or filter manufacturer for the shielded motor supply cable must be observed.



Important: These integrated filters often only allow a maximum length of the shielded motor cable of 5–10 m. The conformity declarations specified in the operating instructions for the frequency converter in respect of the EMC guidelines (e.g. EN 55011, Class A, B) are generally only valid for these relatively short cable lengths. Cable lengths of 50–100 m are often also specified: such cable lengths however do not generally relate to EMC conformity, but to the maximum permitted capacitive load (capacitance of the shielded motor supply cable) which can be supported without difficulty by the frequency converter's output stage. Motor cable lengths >10m can result in significant increases in leakage current. Check with the manufacturer for the required RCD sensitivity to prevent undesired tripping.

There is an increased risk of undesired tripping if the switching frequency of the frequency converter is approximately equal to or a multiple of the resonance frequency of the EMC filter. Many frequency converters reduce their switching frequency automatically at low output frequencies (typically below approximately 20 to 30 Hz, and also when the motor is started up and shut

down). Higher switching frequencies (including higher-order multiples of the resonance frequency) generally minimise the risk of a tendency to oscillation in the EMC filter.

1.4.6 Inductive leakage currents

As mentioned above, leakage currents are generally capacitive currents. Inductive leakage currents are however not unusual, and may occur in particular in electrical systems with very high currents. They therefore tend to occur in the lower frequency range.

Example: electrical system with three-phase operated frequency converter and EMC input filter and motor with shielded traditional four-core motor supply cable (U, V, W, N/PE) with a length of approx. 50 m each. The machine frequency is 20 Hz, and the motor current per phase is approx. 200 A. As a result of the asymmetric internal design of the four-core motor cable, an inductive injected leakage current of several hundred mA may occur at a frequency of 20 Hz in the current path N/PE. Shielded motor supply cables with a symmetric and low-impedance arrangement of the inner conductors should therefore be used wherever possible. This significantly reduces both inductive and capacitive leakage currents.

1.4.7 Changes to existing electrical systems

If changes are made to an existing electrical system which has already been measured for EMC purposes (for example changing filter measures or the switching frequency of a frequency converter), EMC-related measurements must generally be repeated in order to ensure that the system still complies with the relevant applicable EMC guidelines. Checks should also be carried out to ascertain whether reliable tripping of the residual current operated protective device is still guaranteed in the event of faults on the output side of the frequency converter.

1.5 Importance information concerning the use of frequency converters with integrated EMC filters

Many frequency converters are already fitted with an internal EMC input filter, making it unnecessary to use an external filter.

- » Longer supply cables result in magnetic saturation of the EMC filter choke as a result of the increase in asymmetric capacitive currents. The consequence of this is extremely high leakage currents and filter resonance. A saturated filter choke renders the filter ineffective, meaning that the permitted limit values of the relevant EMC guidelines are exceeded by far and the frequency converter becomes a frequently unnoticed source of significant interference for other consumers.
- » If a frequency converter with integrated EMC filter and long shielded motor supply cable (> 10 m) is used, the integrated filter must be deactivated wherever possible and an external EMC filter installed which is suitable for use with long motor supply cables. It may be necessary to carry out EMC measurements on the entire electrical system in order to determine which filter is suitable.

1.6 Measurement of leakage currents

In order to allow the reliable and uninterrupted operation of an electrical system with a residual current operated protective device, it should be ensured that there is no risk of undesired tripping due to high leakage currents in all the various operating states of the electronic equipment.

With this in mind it is useful to measure the leakage current or residual current, which is also recorded by the residual current operated protective device used. In functional terms, the measuring instrument used for this purpose should be almost identical to the residual current operated protective device in terms of the frequency range across which it can measure residual currents and the various frequencies which it can evaluate.



Important: Many of the residual current test devices currently on the market are not suitable for measurements of this kind. They can generally only be used to measure mains frequency currents (50/60 Hz). Even broad-band measuring clamp-on probes generally only provide for a frequency range of up to max. 1 kHz and are often suitable only for measuring currents in the high ampere range. Their detection of leakage currents in the low as well as the higher frequency ranges is unsatisfactory and therefore will not give a true reflection of the actual leakage currents present in the circuit.

A suitable summation current transformer should preferably be positioned in such a way that it is subject to the same flow from the conductors to be monitored as the residual current operated protective device used. The instrument transformer is connected to a measuring unit for signal processing purposes, which in turn is connected to a notebook or PC. A measuring system of this kind is implemented using the residual current analysis system DRCA 1. The software supplied is used to carry out a wide range of measurements (time-based representation of residual current, frequency analysis, frequency-dependent evaluations, recording of very brief signals, long-term measurements etc.) and store the results.

All of the system's operating states (such as switching on and off, start-up and shut-down of individual and (where applicable) multiple frequency converters, drive mode at various machine frequencies etc.) should be taken into account and measured in order to determine the maximum critical leakage current. The measurements which are obtained can be used as a basis for any measures required to guarantee the uninterrupted operation of the electrical system (altering the switching frequency of the frequency converter, using four-wire filters etc.).

1.7 Correct use of an AC-DC sensitive residual current circuit-breaker in an electrical system with electronic equipment

1.1.3 Regulatory-compliant use of AC-DC sensitive residual current operated protective devices

If smooth DC residual currents (no zero point contact) can be expected to occur in electrical systems owing to the presence of particular electronic equipment, the use of an AC-DC sensitive residual current operated protective device is already prescribed in many cases by the relevant standards. This applies e.g. to three-phase operated frequency converters, which generally use a six-pulse bridge connection on the input side in order to rectify the mains voltage (see Fig. 8).

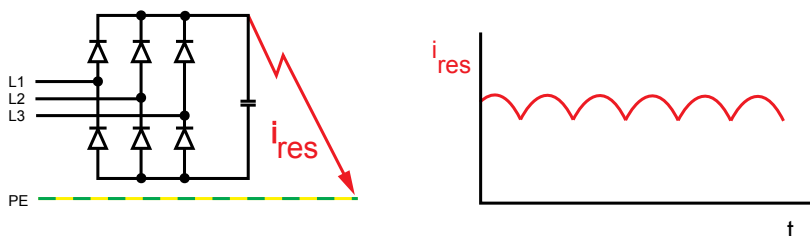

Fig. 8: Six-pulse bridge connection (three-phase AC bridge connection)

HD 60364-5-53:

Low-voltage electrical installations – Selection and erection of electrical equipment – Switchgear and control gear

Section 541.3.3 lists the various types of RCDs (AC, A, F, B) and their tripping behaviour in relation to DC residual currents and AC residual currents \neq rated frequency. Appendix A shows several types of residual currents. This includes currents which only permit the use of Type B RCDs.

UK Wiring Regulations 17th Edition: The risks associated with smooth DC residual currents and the use of the incorrect Types of RCD are not covered in the general text of the existing Regulations.

Following some fatal accidents in Germany, VDE Regulations are very specific about the problem associated with smooth DC residual currents and RCD protection.

VDE 0160 / EN 50178:

Set-up of power installations with electronic equipment

In line with Sections 5.2.11.2 and 5.3.2.3, Type B RCDs must be used to provide protection against direct and indirect contact if electric equipment may produce a smooth DC residual current in the event of a fault

VDE 0100 Part 530: Construction of low voltage installations – Selection and erection of electrical operating equipment – Switching and control devices

In line with Sections 531.3.2 and 532.2, Type B or B+ RCDs must be used if electronic equipment on the load side may produce a smooth DC residual current in the event of a fault. This also applies to fixed-connection electronic equipment if a residual current operated protective device is nevertheless required (e.g. in the TT system).

RCDs with a rated residual current of no more than 300 mA must be used for preventative fire protection.

Note:

As mentioned above, Type A RCDs are not suitable for detecting smooth DC residual currents since they result in pre-magnetization of the summation current transformer and therefore significantly impair functionality. Based on the relevant product standards, the maximum load which may be applied to Type A RCDs in the event of a fault is 6 mA DC, regardless of their rated residual current.

1.7.1 Protective measures when operating frequency-controlled equipment on construction sites.

DGUV Information 203-006 (previously BGI 608): Selection and operation of electrical systems and equipment on construction and assembly sites

- » Before connecting frequency-controlled equipment to a building-site distribution board, checks should be carried out to ascertain whether the integrated residual current operated protective device is suitable for this equipment. If smooth DC residual currents are to be expected in the event

of a fault, the equipment may only be connected if a Type B or B+ residual current operated protective device is present. If temperatures below $-5\text{ }^{\circ}\text{C}$ may occur, the equipment must be suitable for temperatures down to $-25\text{ }^{\circ}\text{C}$.



Note: The following list of applications for AC-DC sensitive residual current operated protective devices is only provided as an example and is not exhaustive. The installer of any electrical system must take the protective measures appropriate for this system as stipulated by the currently applicable provisions.

- » Hand-held electrical consumers
RCDs with a rated residual current of $\leq 30\text{ mA}$ are recommended for use, regardless of the rated current.
- » Electric circuits without sockets (fixed connection):
 - Electric circuits with a rated current of $\leq 32\text{ A}$ must be operated using RCDs with a rated residual current of $\leq 30\text{ mA}$.
- » Electric circuits with sockets:
 - Electric circuits with a rated current of $\leq 32\text{ A}$ must be operated using RCDs with a rated residual current of $\leq 30\text{ mA}$.
 - Electric circuits with a rated current of $> 32\text{ A}$ must be operated using RCDs with a rated residual current of $\leq 500\text{ mA}$.

- » Protective measures when using frequency-controlled equipment:
 - Multi-phase operated electric equipment with frequency converters (e.g. cranes, lifts, welding converters) may only be operated using Type B or B + RCDs, since smooth DC residual currents may occur in the event of a fault. Alternatively, such equipment may be connected via an isolating transformer or a fixed connection (*fixed connection: No RCD up stream*).
 - Single-phase operated electric equipment with frequency converters (e.g. compactors, hammer drills) generate a residual current mix consisting of low-frequency and high-frequency components and a high 50 Hz component in the event of a fault. Smooth DC residual currents cannot occur. Equipment of this kind does not therefore need to be operated using Type B or B+ RCDs. The use of Type F RCDs is recommended.

- » In order to avoid undesired tripping of RCDs, only equipment which produces the lowest level of leakage currents possible is recommended for use.

In special cases, a building-site distribution board with Type B RCDs, intended inter alia for the connection of a construction crane with a multi-phase frequency converter, may be connected to an existing electrical system in which only Type A RCDs are permanently installed. A further example would be the connection of a building-site distribution board with Type B RCDs to an unknown electrical system with unknown protective devices. This arrangement (series connection) of RCDs is however not permitted under DIN VDE 0100-530.

The use of AC-DC sensitive residual current circuit-breakers (MI design) with the designation DFS 4 BSK MI or DFS 4 B+ MI can provide a solution to such problems. When Type B or B+ AC-DC sensitive residual current circuit-breakers of this kind are used, tripping takes place for smooth DC residual currents below 6 mA, meaning that the functionality of upstream Type A or F RCDs is not impaired by unduly high smooth DC residual currents and they are therefore protected. Further information on this topic can be found in the section entitled "Protection when using AC-DC sensitive residual current circuit-breakers (MI design)" in Part II of this brochure.

1.7.2 Use of RCDs in electrical systems with a PV power supply system

BS7671 Section 712: Special types of installations – Solar energy, photovoltaic (PV) power supply systems

According to Section 712.411.3.2.1.2, Type B RCDs must be used if the installation does not contain simple separation (isolating transformer) between the DC and AC side.

If the electrical system is designed in such a way as to provide for simple separation between the inverter and the residual current operated protective device (separate winding transformer or use of an inverter with transformer), a Type A residual current operated protective device may be sufficient.

If the inverter manufacturer has provided written confirmation that no smooth DC residual currents can occur as a result of the use of his PV inverter, a Type A residual current operated protective device may also be sufficient.

Statements by the PV inverter manufacturer claiming that a residual current operated protective device is integrated into the inverter must however be evaluated critically. An RCMU (Residual Current Monitoring Unit) cannot be used in place of an RCD in line with BS7671 clause 411.1. An RCMU cannot however serve as a replacement for a residual current operated protective device, and merely increases the level of protection if the protective measure required on the DC side of a PV system prohibits 'double or reinforced insulation'. It therefore monitors faults on the DC side alone, and switches the PV inverter off if necessary without achieving electrical isolation.

Measurements carried out on PV power supply systems with transformerless inverters using various switching technologies have shown that residual currents with a high smooth DC content (> 6 mA) do indeed occur throughout the entire electrical system in the event of faults on the DC side. The magnitude of the DC content is determined by the PV generator voltage and by the value of the fault and loop resistance. Galvanic coupling between the DC and AC sides, which is only made possible by the flow of a DC residual current throughout the entire PV system, is achieved by the transformerless inverter. These residual currents may result in the pre-magnetization of the summation current transformer of a Type A residual current operated protective device, significantly impairing its functionality.

Additional notes on the use of RCDs in electrical systems with PV power supply systems:

- » The majority of PV installations using transformerless inverters produce operational leakage currents which preclude the use of 30mA RCDs on the AC supply cable. Therefore before designing a system which relies on additional protection provided by an RCD, refer to PV inverter manufactures instructions.
 - » 712.411. Automatic disconnection under fault conditions: In addition to TT earthing systems, to achieve the required disconnection times, some TN systems may also require the use of an RCD on the a.c. PV supply cable - see 411.3.2.3
 - » In certain electrical systems, RCDs are necessary regardless of the supply earthing system e.g. in agricultural premises - see 705.411.1 stipulates a maximum residual operating current of 300mA*
 - » Precautions where particular risks of fire exist (422.3), section 532 .1 stipulates a maximum residual operating current of 300mA*
- * The operational leakage current of the complete PV system will change according to ambient conditions, therefore an allowance should be made for increases in leakage current during operation in damp or humid conditions.
- * Refer to the PV inverter manufactures recommendations with regard to minimum RCD sensitivity to prevent unwanted tripping, before designing the installation and making a final product selection.

Example of an electrical system with a PV power supply system see over:

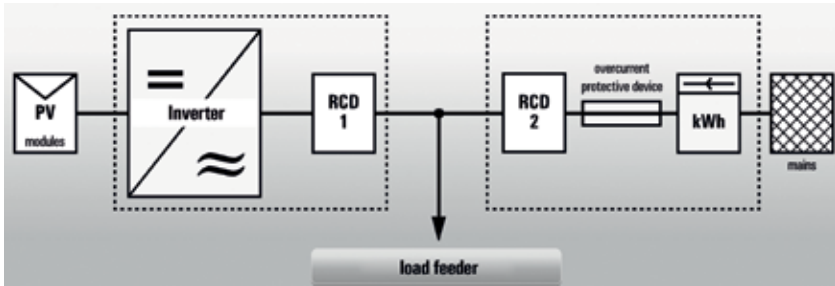

In systems where protection through automatic switch-off using overcurrent protective devices cannot be achieved:		RCD 1		RCD 2	
		without load feeder	with load feeder **	without load feeder	with load feeder **
Inverter protection class I without switching point/RCMU	Inverter without transformer	-	Type B *	Type B *	Type B *
	Inverter with transformer	-	-	Type A	Type A
Inverter protection class I with switching point/RCMU	Inverter without transformer	-	-	Type B	Type B
	Inverter with transformer	-	-	Type A	Type A
Inverter protection class II without switching point/RCMU	Inverter without transformer	-	-	Type B *	Type B *
	Inverter with transformer	-	-	-	Type A
Inverter protection class II with switching point/RCMU	Inverter without transformer	-	-	-	Type B
	Inverter with transformer	-	-	-	Type A

independently of the supply system (TN, TT) of the low voltage network:
 * According to VDE V 0126-1-1 (Section 4.7.1), if a transformerless inverter does not contain an RCMU then RCDs with a rated residual current of ≤ 30 mA must be used on the AC side for the purpose of personal protection on the DC side (high leakage currents may however potentially occur and must be monitored).
 ** for load feeder with sockets (laypersons, exterior): $I_{\Delta n} \leq 30$ mA or additional residual current operated protective device in the load feeder with $I_{\Delta n} \leq 30$ mA (see VDE 0100-410, Section 411.3.3).
 Note: Type B+ RCDs can also be used instead of Type B RCDs.

Use of RCDs with and in electric machines

A distinction should be made between RCD protection for the cable feeding the equipment (refer to BS7671 installation regulations) and an RCD installed in the equipment (refer to BSEN60204-1).

VDE 0113-1 (EN 60204-1): Safety of machines – Electrical equipment for machines – Part 1: General requirements

Pursuant to Section 6.3, measures must be taken to achieve fault protection (protection in the event of indirect contact) in machines. If machines are used in TT systems, RCDs must be integrated into the machines as components.

A power supply isolating device must also be installed. The latter must meet the requirements for isolating devices pursuant to IEC 60947-1. These requirements are met generally by circuit-breakers pursuant to IEC 60947-2.

The ideal combination of both protective measures can be found in the form of a circuit-breaker with residual current trip (CBR) in line with IEC 60947-2 (Annex B) or a modular residual current operated protective device (MRCD) in line with IEC 60947-2 (Annex M). Our CBRs in the DFL 8 series and our MRCDs in the DMRCD series are available in various designs.

If electronic equipment which may produce smooth DC residual currents in the event of a fault is integrated into the machine (e.g. multi-phase operated frequency converters), any residual current operated protective device needing to be installed must be of Type B or B+.

1.7.3 Additional uses for AC-DC sensitive residual current devices

BS7671 Section 704: Construction and Demolition sites

The majority of sites may use work equipment containing inverters which are not compatible with Type AC RCD protection.

The existing edition of the regulations (Amendment 3) does not highlight the risks associated with inverter/frequency controlled equipment connected to RCD protected circuits. However Guidance Note 1 Amd.3 (411.4) makes reference to the "Types" of RCD and their suitability for the protection based on the nature of the residual current associated with the load.

For guidance refer to the Electricity at Work Regulations 4(1) 64 a,b,c etc.

BS7671 Section 722: Power supply of electric vehicles

When charging electric vehicles, according to Section 722.531.3 every connection point (socket) must be protected by a residual current operated protective device with a rated residual current of ≤ 30 mA, unless the corresponding electric circuit incorporates protective separation as a protective measure. Charging stations with sockets or connectors in line with DIN EN 62196 must include precautionary measures against DC residual currents. Type B RCDs may be used for this purpose. Alternatively, Type A

RCDs may be used, if it has been ensured that an additional function or an additional device records smooth DC residual currents and switches off at a maximum value of 6 mA, meaning that the reliable functioning of the Type A residual current operated protective device is guaranteed.

The Type A residual current circuit-breaker DFS 4 EV has an additional function for recording smooth DC residual currents, and so no additional devices are required.

Important: This residual current circuit-breaker may only be used to protect electric circuits for charging electric vehicles in line with DIN VDE 0100-722.

BS7671 Section 710: Medical Locations

Regulation 710.411.3.2.1 Group 1 & 2 locations require the use of Type A or Type B RCDs - refer to the medical equipment manufacturers installation instructions. Type AC devices must not be used.

1.8.6 Additional guidelines requiring Type B RCDs:

(Specific notes relating to the export of equipment to Germany)

German Insurance Association Certification Requirements relating the Installation of equipment containing frequency inverters:

VdS 3501: Damage prevention guideline: Protection against insulation defects in electrical installations with electronic equipment – RCDs and frequency converters

As per Section 4.4, a Type B+ RCD with a rated residual current of ≤ 300 mA is to be provided for fire protection in facilities at risk of fire. The RCD must reliably detect residual currents over a frequency range of 0 to 20 kHz and have a maximum tripping threshold of 420 mA, which may not be exceeded over the entire frequency range.

An even higher protection level can be achieved with AC-DC sensitive RCDs, which have a frequency range of at least 100 kHz with a maximum tripping threshold of only 300 mA. This allows for extremely high-frequency residual currents to be reliably detected, for example in the wood and paper processing industry, as machines with frequency converters that operate with switching frequencies > 20 kHz can also be used here.

Additional guidelines requiring Type B RCDs continued :

DGUV Information 201-002 (previously BGI 530): Structural engineering work

DGUV Information 201-013 (previously BGI 665): Demolition work

DGUV Information 203-032 (previously BGI 867):

Emergency generators on construction and installation sites

DGUV Information 201-044 (previously BGI 5087):

Stone working, stone processing

DGUV Information 201-049 (previously BGI 5103): Civil engineering

VdS 2033: Damage prevention guideline: Electrical systems in facilities at risk of fire and risks equivalent to these

VdS 2046: Safety regulations for electrical systems up to 1000 volts

VdS 2067: Damage prevention guideline:

Electrical systems in agriculture

1.9 Division of electric circuits

To meet the requirements of Regulation 532.1 (i) Electric circuits with electronic equipment such as frequency converters must not be connected to a circuit protected by an RCD which is not suitable for the connected equipment. See example HD 60364-5-53 Annex A Figure A.2,

Using the incorrect Type of RCD could result in the loss of protection and an increased risk of fire due to the flow of high leakage currents to earth.

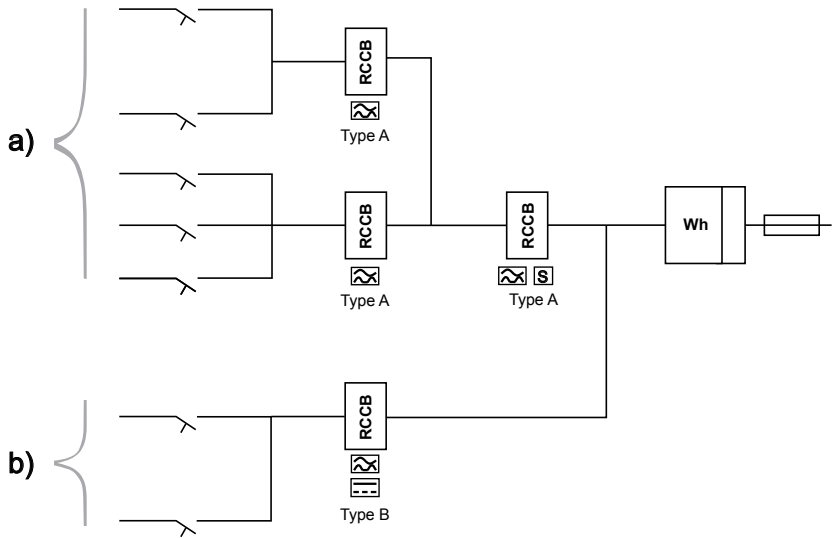

Fig. 9: Division of electric circuits in systems with electronic equipment
(source: DIN VDE 0160 / EN 50178, HD 60364-5-53 Annex A Figure A.2)

- a): Electrical circuits in which only AC residual currents and/or pulsating DC residual currents can arise in the event of a fault.
- b): Electrical circuits in which smooth DC residual currents can also arise in the event of a fault.

1.10 RCDs as protection via automatic power supply switch-off in the event of a fault

According to Regulation 531, RCDs are used as protection against electric shock via automatic power supply switch-off or as fire protection. In electrical systems with electronic equipment in which smooth DC residual currents can be generated, only Type B RCDs will provide the required level of protection e.g. a residual current circuit breaker without (RCCB) and with (RCBO) integrated overcurrent protection, a modular residual current operated protective device (MRCD) or a Type B or B+ circuit-breaker with residual current protection (CBR).

RCMs (*residual current monitors*) in conjunction with a switching device with isolating function are only permitted as fire protection in exceptional cases where RCDs can no longer be used due to a very high operating current. Our CBRs in the DFL 8 series and our MRCDs in the DMRC series are available in various designs, inter alia for very high rated currents, meaning that the exceptional use of RCMs for fire protection is unnecessary. In industrial settings, MRCDs with a rated residual current of ≤ 30 mA may be used for additional protection (personal protection). Like RCMs, MRCDs consist of an evaluation device with an external summation current transformer and a switch-off device prescribed by the manufacturer (e.g. a circuit-breaker).

RCMs may not be used as protection via automatic power supply switch-off. They are ideal for use together with a residual current operated protective device, however. Our AC-DC sensitive RCMs in the DRCM series are fitted with a multi-digit display and a pre-alarm. This makes it easy to monitor the residual current. If an adjustable threshold is exceeded, a signal is emitted before the power supply is automatically switched off using the residual current operated protective device if the residual current continues to increase.

1.11 Basic circuits for electronic equipment and the potential residual currents which may result

The following table shows the time curve for the load and fault current for electronic equipment with various basic circuits, as well as specifying the RCD types suitable for comprehensive protection.

No.	Circuit diagram with fault location	Shape of load current	Shape of residual current	Tripping characteristics				
				AC	A	F	B	B+
1	<p>single-phase without rectification</p> <p>L1 L2 L3 N PE</p>			✓	✓	✓	✓	✓
2	<p>leading edge control</p> <p>L1 L2 L3 N PE</p>			✓	✓	✓	✓	✓
3	<p>burst control</p> <p>L1 L2 L3 N PE</p>				✓	✓	✓	✓
4	<p>single-phase</p> <p>L1 L2 L3 N PE</p>				✓	✓	✓	✓
5	<p>two-pulse bridge rectifier</p> <p>L N PE</p>				✓	✓	✓	✓
6	<p>half-controlled two-pulse bridge rectifier</p> <p>L N PE</p>				✓	✓	✓	✓
7	<p>frequency converter with two-pulse bridge rectifier</p> <p>L N PE</p>					✓	✓	✓
8	<p>single-phase with filtering</p> <p>L1 L2 L3 N PE</p>						✓	✓

No.	Circuit diagram with fault location	Shape of load current	Shape of residual current	Tripping characteristics				
				AC	A	F	B	B+
9	<p>frequency converter with two-pulse bridge rectifier and PFC stage</p>						✓	✓
10	<p>two-pulse bridge rectifier between line conductors</p>						✓	✓
11	<p>frequency converter with two-pulse bridge rectifier between line conductors</p>						✓	✓
12	<p>AC star circuit</p>						✓	✓
13	<p>six-pulse bridge rectifier</p>						✓	✓
14	<p>frequency converter with six-pulse bridge rectifier</p>						✓	✓

1.12 Formation of a smooth DC residual current from the individual currents of the line conductors L1, L2 and L3

Simplified circuit consisting of a three-phase network with B6 bridge connection of the frequency converter and insulation fault.

The residual current i_F is calculated by adding together the individual currents i_{L1} , i_{L2} and i_{L3} in the three conductors L1, L2 and L3. The individual conductor currents i_{L1} to i_{L3} represent pulsating DC residual currents with longer zero point contact, resulting from the commutation of three of the six rectifier diodes. Their individual magnetic fluxes are added up in the transformer core. The result is a magnetic flux which is proportional to the residual current i_F with a high direct component, which leads to the pre-magnetization of the transformer core and greatly restricts or even prevents further DC magnetization by any DC residual currents which may still be present.

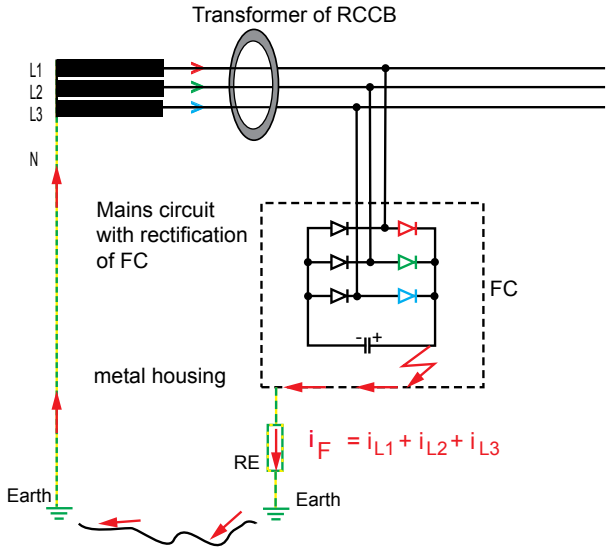

Fig. 10: Effect of an insulation fault at the intermediate circuit capacitor with six-pulse bridge connection

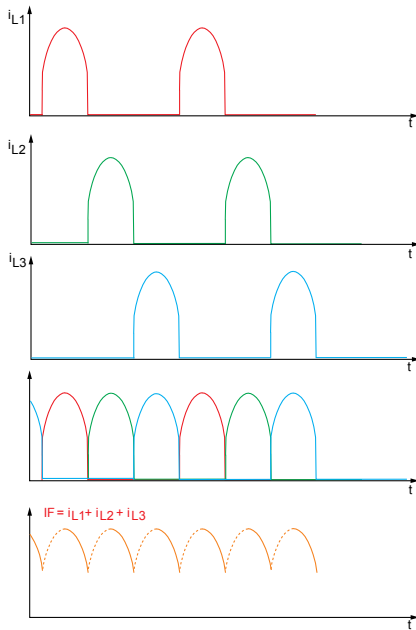

Fig. 11: Representation of individual conductor currents

Part II

The frequency response of the tripping current of AC-DC sensitive RCDs and its significance for the level of protection

protection level (level of protection; safety level); The protection level refers to the level of safety achieved by an installation, from basic fire protection through to the most comprehensive possible personal protection.

frequency response (*also*: frequency spectrum); residual currents are increasingly composed of a series of different discrete frequencies. The frequency response provides information on the amplitude of the discrete frequency components.

2. The frequency response of the tripping current of AC-DC sensitive RCDs and its significance for the level of protection

2.1 Protection by Type A RCDs which are sensitive to pulsating currents

Conventional residual current operated protective devices in line with EN 61008/ VDE 0664 Part 10 which are sensitive to pulsating currents are designed for Type A residual currents in line with IEC TR 60755 (*General requirements for residual current operated protective devices*), i.e. their intended purpose is solely to respond to AC residual currents and pulsating DC residual currents at their rated frequency, or in other words the mains frequency. The response thresholds for residual currents with different frequencies are not defined. Tripping is therefore not guaranteed by these RCDs for smooth DC residual currents or higher-frequency AC residual currents. Too large a direct component in the residual current can even prevent tripping as a result of the mains-frequency AC residual current. The level of protection achieved by a Type A RCD, as shown in Table 1, is determined by its rated residual current at rated frequency.

Rated residual current $I_{\Delta n}$	Level of protection (at rated frequency)		
	Fault protection ¹⁾	Fire protection ²⁾	additional protection ³⁾
0.03 A	✓	✓	✓
0.1 A	✓	✓	
0.3 A	✓	✓	
> 0.5 A	✓		

- 1) Previously referred to as protection against indirect contact i.e. in the event of a single earth fault the RCD will disconnect the equipment before metal parts are touched.
- 2) Protection against electrically initiated fires due to earth leakage currents.
- 3) Previously referred to as protection against direct contact i.e. in the event of a person touching a live conductor the RCD will disconnect the supply, reducing the the time of the shock exposure.

Table 1 Assignment of achievable level of protection to rated residual current for Type A RCDs

2.2 Protection by Type F RCDs

Type F RCDs meet all requirements for Type A RCDs which are sensitive to pulsating currents and also detect residual currents with mixed frequencies other than 50 Hz. They are intended for use in electrical systems incorporating electronic equipment which may generate residual currents which contain low-frequency and high-frequency components as well as a high 50 Hz component (e.g. when using single-phase operated frequency converters). This ensures that if the residual current has low-frequency and high-frequency components, tripping is not prevented at the 50 Hz component (which is present in the residual current with sufficient amplitude). This cannot be guaranteed with sufficient certainty for Type A RCDs.

Type F RCDs are not suitable for the detection of smooth DC residual currents and therefore in no way replace Type B or B+ RCDs.

The product standard DIN EN 62423 sets out requirements for Type F RCDs. Type F RCDs are now listed in HD 60364-5-53 (531.3.3) and will be required to provide suitable detection of residual currents in circuits supplying white goods containing single phase inverters which produce mixed frequency leakage currents such as washing machines.

2.3 Protection when charging electric vehicles using DFS 4 A EV

Type A RCCBs with the designation DFS 4 A EV contain an additional function which detects smooth DC residual currents and effects a switch-off if these DC residual currents exceed a value of 6 mA. These circuit-breakers may only be used for protection when charging electric vehicles in line with DIN VDE 0100-722. They may not be used for any other applications. Alternatively type B RCCBs may be used in this case. DFS 4 A EV may not be used as a replacement for Type B or B+ RCDs under any circumstances. Circuit-breakers with the designation DFS 4 A EV only detect Type A residual currents (AC and pulsating residual currents at the rated frequency of 50 Hz), as well as smooth DC residual currents (switch-off at max. 6 mA) thanks to the integrated additional function. Residual currents with frequencies \neq 50 Hz, such as those which may be produced in electrical systems with frequency converters, are not detected. Only Type B or B+ RCDs may be used in these cases. In addition, the

minimum permissible tripping threshold for smooth DC residual currents when Type B or B+ RCDs are used always corresponds to 0.5 times the rated residual current and is therefore significantly greater than 6 mA.

2.4 Protection when using AC-DC sensitive residual current circuit-breakers (MI design)

AC-DC sensitive residual current circuit-breakers (MI or mobile installation design) with the designation DFS 4 B SK MI or DFS 4 B+ MI by Doepke are intended for use in mobile distribution boards (e.g. building-site distribution board) in order to maintain the reliable functioning of existing or unknown upstream RCDs. They meet all the requirements of currently applicable product standards for AC-DC sensitive Type B or B+ residual current circuit breakers, with the following exceptions. The tripping value for smooth DC residual currents is below 6 mA. The laws of physics dictate that the tripping values for pulsating DC residual currents are also below the lower limit values specified in the product standards. In spite of the lower tripping values for smooth and pulsating DC residual currents, these residual current circuit-breakers demonstrate increased surge current strength and also meet the requirements of ÖVE ÖNORME 8601 (resistance to lightning).

Product standards for Type B or B+ AC-DC sensitive RCDs stipulate that tripping must occur for a smooth DC residual current at between 0.5 and 2 times the value of the rated residual current. If Type B or B+ AC-DC sensitive RCDs are used for additional protection with a rated residual current of 30 mA, tripping in the event of a smooth DC residual current must occur between 15 and 60 mA. Regardless of the rated residual current, however, a smooth DC residual current which is applied to a Type A RCD which is sensitive to pulsating currents may not exceed 6 mA. Higher values will result in the magnetic saturation of the summation current transformer, which may lead to its ineffectiveness.

Due to the maximum tripping value of 6 mA for a smooth DC residual current, AC-DC sensitive residual current circuit-breakers (MI design) may however be connected downstream of Type A or F RCDs which are sensitive to pulsating

currents, although DIN VDE 0100-530 makes no provision for an arrangement of this kind. Undue magnetic saturation of the summation current transformer of upstream Type A or F RCDs cannot occur in this case. This guarantees the protective function of upstream Type A or F RCDs which is provided for by the standards.

Type B or B+ AC-DC sensitive residual current circuit-breakers in Doepke's new MI design correspond to the current state of the art. The standards which are currently applicable do not yet take into account their unique tripping characteristic. The arrangement of RCDs described above (series connection) however represents a solution which complies with the current state of the art in order to meet the requirements of the relevant CE guidelines in terms of conformity evaluations.

2.5 **The frequency response of the tripping current for AC-DC sensitive RCDs and its significance for the level of protection**

In electrical systems with electronic equipment which is not galvanically isolated from the mains, smooth DC residual currents or residual currents with frequencies or mixed frequencies which differ greatly from the mains frequency may occur in the event of an earth fault. In order to achieve residual current protection in systems with equipment of this kind, a residual current operated protective device is required which goes beyond the traditional use of the term "AC/DC" and is AC-DC sensitive, i.e. which guarantees broad-range detection of residual currents at all the frequencies which may occur in the system and effects a disconnection if necessary. It is also debatable whether the level of protection dictated by the rated residual current for the rated frequency can also be assumed for the entire remainder of the frequency range detected by the residual current operated protective device. Here, a detailed evaluation is possible with the residual current analysis software DRCA 1 which observes the tripping behaviour of the RCDs at different frequencies.

2.6 Protection by Type B RCDs with extended frequency range for the response current (AC-DC sensitive RCDs)

Many types of power electronics equipment, such as uninterrupted power supplies, photovoltaic inverters or frequency converters, generate a bipolar square wave voltage (pulsed direct voltage) from smooth direct voltages, either internally or directly as an output voltage; this bipolar square wave voltage modulates the sinusoidal output voltage with the desired output frequency as a result of pulse width modulation. This means for example that frequency converters may cause not only residual currents at mains frequency and smooth DC residual currents in the event of a fault, but also residual currents with a frequency mix of the clock frequency with its harmonic components and the output frequency. In order to guarantee comprehensive residual current protection even if such equipment is used, the residual current operated protective device used for this purpose must therefore also trip in response to smooth DC residual currents and AC residual currents at these frequencies.

In practice, this means that RCDs must respond accurately to residual currents at all frequencies from 0 Hz up to the highest conceivable clock frequency of the equipment that the desired level of protection is guaranteed not only at the rated frequency, but across the entire frequency range. This is the only way to avoid miscalculating the scope of protection achievable when selecting a residual current operated protective device on the basis of its rated residual current.

However power electronics equipment frequently causes high leakage currents, which may also result in the unintended tripping of RCDs. The frequency response threshold of the residual current operated protective device should therefore be only slightly below the limit necessary to achieve the desired level of protection. RCDs with a response characteristic of B meet these requirements to a greater or lesser extent, depending on the standard according to which they are designed.

2.7 Requirements applicable to the magnitude of the tripping current on the basis of frequency

In order to guarantee a uniformly high level of protection across the entire frequency range, the residual current response of a Type B residual current operated protective device does not necessarily need to be smaller than or equal to the rated residual current at all frequencies. RCDs for personal protection must therefore be known to respond to residual currents with a frequency of 50 Hz at a maximum of 30 mA. The permitted response threshold may however be significantly higher for a DC residual current or residual currents at higher frequencies, since the human body responds less sensitively in terms of potential cardiac injuries to these currents than to a 50 Hz AC current. Fig. 12 shows how the frequency response of the tripping current of AC-DC sensitive RCDs can be adjusted to the frequency-dependent current sensitivity of humans in order to achieve the broadest possible protection against faults and additional protection (personal protection) without the residual current operated protective device always responding at a threshold of 30 mA for residual currents at the various frequencies, or in other words with an unnecessary level of sensitivity. Information on the risk of currents passing through the human body at frequencies not equal to 50 Hz can be found in Part 2 of IEC TS 60479 (*Effects of current passing through the human body*) in the form of a hazard curve for frequencies from 50 to 1000 Hz. Using frequency as a basis, it specifies current limit values as a multiple of the limit value permissible at 50 Hz, above which the human body may suffer an electric shock resulting in fatal ventricular fibrillation as a result of longitudinal current flow exceeding the duration of a cardiac cycle. Curve (a) in Fig. 132 is an expanded version of the hazard curve on the basis of information from Part 1 of IEC TS 60479, including frequencies below 50 Hz converted to absolute current values for a probability of occurrence of < 5%.

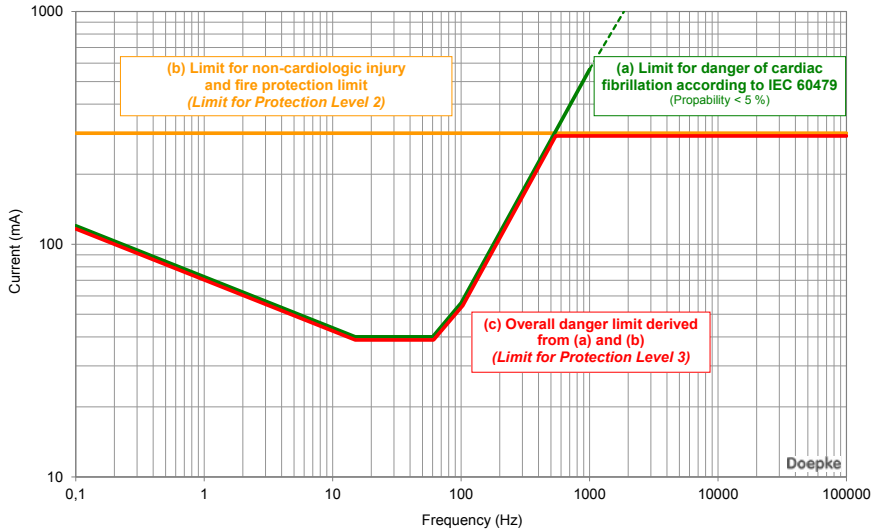

Fig. 12: Hazard limit values for various effects of current passing through the human body

RCDs intended solely to protect humans against this cardiac effect of currents may therefore have a frequency response equivalent to the tripping current, the upper limit of which rises steeply upwards as the frequency increases (as shown by curve (a) in Fig. 13). They would therefore have an extremely low sensitivity of response to residual currents at higher frequencies and would therefore be largely immune to undesired tripping by leakage currents at these frequencies.

RCDs of this kind would not, however, provide the human body with adequate protection against other electropathological effects of currents (such as e.g. thermal and electrochemical effects at high frequencies), since the current limits acceptable for these effects require lower response values. IECTS 60479-1 does not make any direct stipulations concerning the thermal and electrochemical effects of alternating currents. It can however be assumed that alternating residual currents up to 100 Hz passing through the human body will not give rise to effects which exceed those described in Section 4.4 of IECTS 60479-1 for direct currents with the same effective value.

Irreversible damage can therefore be expected even from exposure to high-frequency AC currents at strengths of 0.3 A, even if the exposure only lasts for a matter of minutes. A residual current above this limit must therefore never pass through a human body for an extended period.

Curve (a) in Fig. 13 only falls below this current value in the frequency range up to approx. 500 Hz (hazard curve (b)), i.e. above this frequency the cardiac effect is outweighed by the human body's sensitivity to the thermal and electrochemical effects of the current. A hazard curve which takes account of as many effect mechanisms as possible must therefore not rise arbitrarily in step with curve (a) as the frequency increases; instead, it must level out at a constant value when a particular level is reached (maximum 0.3 A) on the basis of the above discussion.

In order to exclude insofar as possible any risk from all three effects of the residual current, the tripping current of AC-DC sensitive RCDs for extensive personal protection must therefore remain below the overall hazard curve (c) through the entire frequency range covered. RCDs with a rated residual current of 0.03 A and a rated frequency of 50 Hz may therefore have tripping thresholds



Note: The current limit of 0.3 A, which was selected as a result of the meagre and inexact information provided in IEC 60479-1, means that complete protection through automatic switch-off cannot be expected in the event of direct contact. In a worst-case scenario, higher-frequency currents below this limit passing through a human body may also render the individual incapable of freely releasing the conductor carrying live voltage. Due to the fact that the permitted current flow duration is relatively long, however, the likelihood that the individual will receive external assistance or will manage to release themselves is many times higher than in respect of the cardiac effect of a 50 Hz current. The value of 0.3 A represents a compromise between a high tripping threshold to avoid faulty tripping due to leakage currents and the lowest possible threshold for safety reasons. Personal protection (protection against direct contact) may only ever be regarded as additional protection, i.e. as an "emergency brake" in the event that the basic protection and the fault protection fail.

which are higher than that at the rated frequency of 50 Hz at frequencies above 100 Hz. The frequency-dependent value of 0.3 A should however not be exceeded for frequencies of > 600 Hz.

The limit value of 0.3 A for the tripping current of RCDs has furthermore long been the upper limit stipulated by experts for protection against fires caused by residual currents. Something which is obvious in the case of Type A RCDs which are sensitive to pulsating currents for the lower protection levels 2 and 1, namely that the protection levels can be achieved for residual currents of all frequencies up to the upper limit frequency, is also true for highly AC-DC sensitive Type B RCDs suitable for a higher protection level (protection level 3). If the tripping current frequency response of a Type B residual current operated protective device meets the above requirements, fire protection is also guaranteed for all the residual current frequencies detected.

2.8 Requirements applicable to the upper frequency limit of residual current detection

The output voltages of power electronics equipment can be clocked with very different frequencies. The frequency spectrum of the potential residual currents is therefore correspondingly wide. A residual current at the output of a three-phase operated frequency converter in a 50 Hz network contains components at several frequencies: the clock frequency and its harmonic components, the motor frequency and the frequency of 150 Hz, which is produced by the six-pulse rectifier as the ripple of the intermediate circuit voltage. The example depicted in Fig. 13 shows the extent to which the various frequency components are contained in the total residual current, depending on the motor frequency f_{Mot} which is set. The total residual current $I_{\Delta\text{Sum}}$ is calculated by geometric addition of the residual current components $I_{\Delta\text{Mot}}$, $I_{\Delta\text{Takt}}$ and $I_{\Delta 150}$, i.e. the partial currents at the motor current frequency, the clock frequency and the ripple frequency of the intermediate circuit direct voltage.

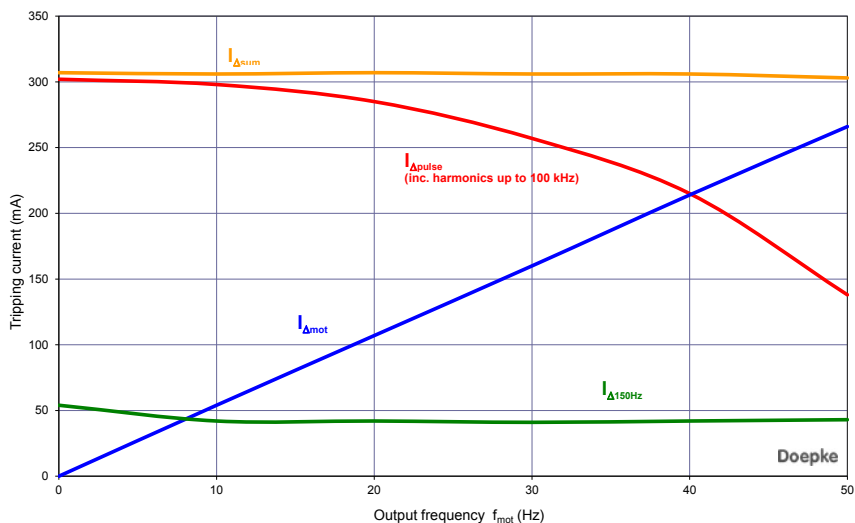

Fig. 13: Residual current components of various frequencies at the output of a three-phase operated frequency converter at a clock frequency of 8 kHz and a fault loop resistance of 780 ohm

Fig. 13 makes it clear that at low motor frequencies (f_{Mot}), the residual current component $I_{\Delta Takt}$ at the clock frequency accounts for almost all of the total effective value of I_{Sum} . Since the clocked output voltage consists of square wave pulses, it contains not only components at the elementary frequency, but also a significant proportion of odd-numbered harmonic components. Popular frequency converters available on the market today can be operated at clock frequencies of up to 16 kHz, meaning that residual currents can also be produced at this square-wave frequency. The first harmonic component (48 kHz) has an amplitude of up to 30% of the 16 kHz fundamental component and therefore represents approx. 10% of the effective value of the total residual current. Even if standard frequency converters are used, the upper limit frequency for residual current tripping should therefore be at least 50 kHz. Converters with higher clock frequencies are also offered for rapidly rotating machines.

Other electronic equipment such as PV inverters, UPS units and switching power supplies are also generally clocked at higher frequencies, meaning that the residual current operated protective device should detect residual current components at frequencies of up to at least 100 kHz in order to provide comprehensive protection.

2.9 Frequency response for a consistent level of protection against low or medium leakage currents

Fig. 15 uses the example of a residual current circuit-breaker DFS 4 B NK with a rated residual current of 30 mA in order to show the frequency responses of the tripping current for RCDs optimised in line with the above requirements. In all frequency ranges, the characteristic curve runs below the total hazard curve (c) from Fig. 13. Based on current understanding, the switch with the rated residual current 30 mA also offers fault protection, fire protection and extensive (although not absolute) personal protection above the frequency of 1000 Hz up to 100 kHz. The response threshold of the tripping current is always just below the permitted maximum limit for protection level 3. This ensures that undesired tripping as a result of leakage currents in the kHz range are largely avoided at a consistently high protection level of 3. The earth resistance necessary for fault protection must be designed on the basis of the highest tripping current in the frequency range detected, i.e. 0.3 A, rather than the rated residual current. The frequency response of the tripping current for AC-DC sensitive residual current circuit-breakers in the DFS 4 B NK series is also designed in such a way that the level of protection assigned to the rated residual current in Table 2 applies to the entire frequency range over which the residual current is detected. For example, the frequency response of the residual current circuit-breaker DFS 4 B NK (Fig. 15) at a rated residual current of 0.3 A is below 0.3 A throughout the entire range detected. According to Table 1, it therefore offers protection level 2 at high frequencies of the residual current as well as at the rated frequency.

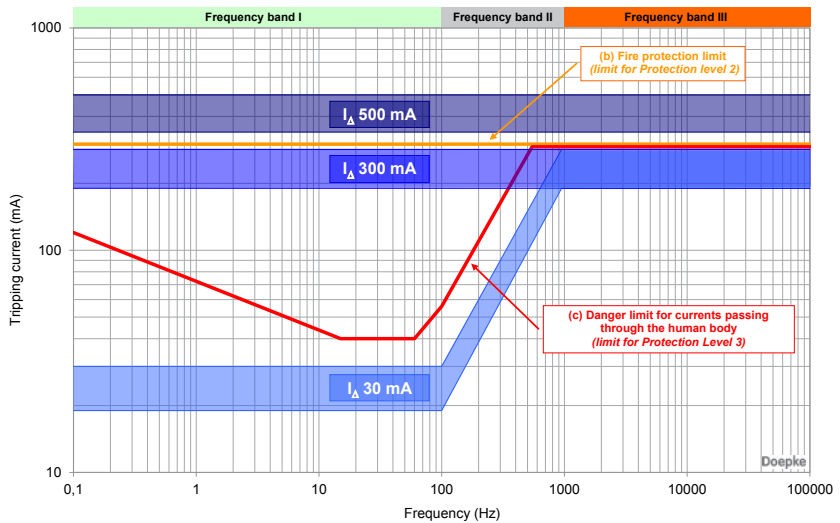

Fig. 14: Frequency responses of the tripping current for the residual current circuit-breaker DFS 4 B NK in relation to the hazard limits for personal and fire protection

2.10 Frequency response with a "change in protection level" in systems with high leakage currents

In systems with several frequency converters and/or long motor supply cables, residual current circuit-breakers which offer a uniform protection level across frequencies may cause undesired tripping as a result of high leakage currents in frequency band III (Fig. 15). In such cases the tripping current of the residual current operated protective device must be higher in this frequency range, which corresponds to a reduction in the level of protection by one or even two levels. As of a particular frequency, the level of protection therefore jumps to a lower level within the frequency range. Fig. 15 provides a qualitative representation of these frequency responses using the example of various residual current circuit-breakers of type DFS 4 B SK.

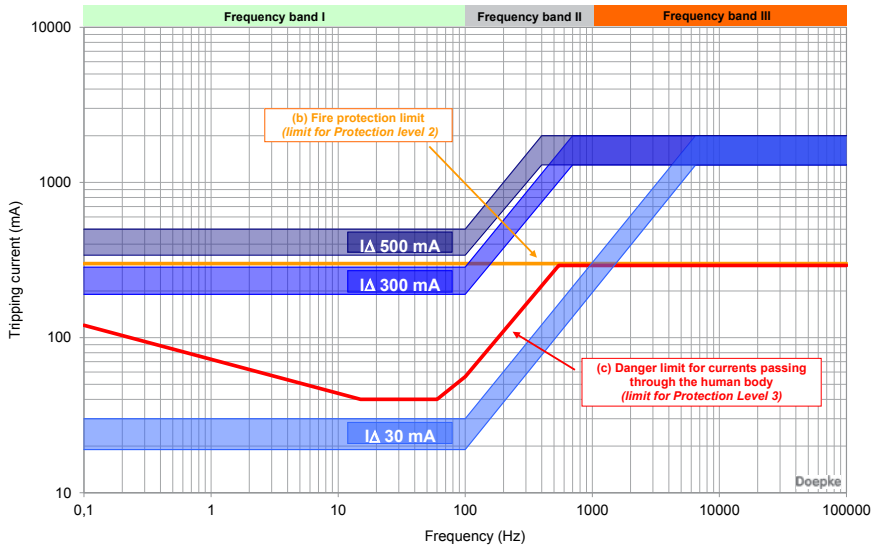

Fig. 15: Frequency responses of the tripping current for the residual current circuit-breaker DFS 4 B SK in relation to the hazard limits for personal and fire protection

The frequency response of the residual current circuit-breaker at a rated residual current of 30 mA is only below the total hazard curve (c) (thus offering protection level 3) in frequency ranges I and II. In range III, however, the response threshold continues to increase in step with frequency, and then levels out at a constantly high value of 2 A until the end of the range detected. These circuit-breakers are therefore largely protected against undesired tripping as a result of leakage currents at the clock frequency of the electronic equipment. This immunity to high-frequency leakage currents is however achieved at the price of a lower level of protection in the higher-frequency range. The level of protection only corresponds to level 3 (i.e. the level expected in line with Table 1) in frequency bands I and II. In frequency range III, however, "only" level 1 can be achieved with this type of circuit-breaker, namely "protection in the event of indirect contact" (fault protection). A jump in the level of protection, from fire protection to exclusively fault protection, also occurs in the case of RCDs with a rated residual current of 0.3 A in step with rising residual current frequency. Fault protection can however also be easily achieved for these high frequencies.

The earth resistance for the constant tripping current which is defined precisely (albeit at a high level) for the remainder of frequency range III is specified to this end.

2.11 Requirements laid down in standards in relation to the tripping current frequency response

The properties and therefore the tripping frequency responses of Type B residual current circuit-breakers are described in the international standards IEC 62423 and IEC TR 60755, in the German standard DIN EN 62423 (VDE 0664-40) and in the German standard DIN VDE 0664-400 (Type B+ RCCBs). FI/LS switches are also covered by the German standard DIN VDE 0664-401 (Type B+ RCBOs).

The requirements which apply to tripping frequency responses differ in some cases in terms of the maximum permissible tripping thresholds and the highest tripping frequency.

In Germany, the standard DIN EN 62423 (VDE 0664-40) on the one hand and the standards DIN VDE 0664-400 and DIN VDE 0664-401 on the other hand make a distinction between Type B RCDs and Type B+ RCDs .

Type B RCDs must detect residual currents up to an upper limit frequency of only 1 kHz, whereby the tripping current may rise to 14 times the rated residual current at higher frequencies. By way of contrast, Type B+ devices must cause tripping up to a frequency of 20 kHz, and the tripping current may not exceed 420 mA at any frequency. This specification also applies to Type B+ RCDs with rated residual currents > 30 mA. This is intended to achieve an improved level of fire protection compared to Type B RCDs ¹.

Note:

The authorised German draft standards E DIN VDE 0664-100 for Type B RCCBs and E DIN VDE 0664-200 for Type B RCBOs have been replaced by DIN EN 62423 (VDE

¹ The limit of 420 mA does not correspond to the rated residual current of 300 mA required for many years for fire protection purposes, but our experience with Type A RCDs has revealed that they too provide adequate protection against electrically ignited fires. Type A RCDs with a rated residual current of 300 mA are also characterised by a higher response threshold of up to 420 mA for pulsating DC residual currents.

0664-40). In addition, the preliminary standard DIN V VDE V 0664-110 for Type B+ RCCBs has been replaced by the standard DIN VDE 0664-400, and the preliminary standard DIN V VDE V 0664-210 for Type B+ RCBOs has been replaced by the standard DIN VDE 0664-401. The content of these standards is identical to that of the preliminary standards.

Our residual current circuit-breakers DFS 4 B NK comply with all currently applicable standards for AC-DC sensitive residual current circuit-breakers. With an upper limit frequency of 100 kHz at a tripping threshold of < 300 mA, they exceed the requirements of these standards and thus significantly extend the scope of protection provided. We therefore recommend that these RCDs should be used wherever possible.

If use of a circuit-breaker in the DFS 4 B NK series appears impossible due to high leakage currents, attempts should always be made initially to reduce the leakage currents. The devices DFS 4 B+ or DFS 4 B SK should only be used if this proves infeasible.

2.12 Earth resistances for fault protection

Unlike in systems with Type A RCDs which are sensitive to pulsating currents, the earth resistance (RE) in systems with AC-DC sensitive Type B RCDs may not be determined using the rated residual current ($I_{\Delta n}$); instead, the maximum tripping current in the frequency range detected must be used ($I_{\Delta Amax}$). On the basis of the interrelationship $RE = UB / I_{\Delta Amax}$, the standard procedure can then be followed to calculate the maximum permissible earth resistance (RE) as follows. The permissible touch voltages UB can be based on the values known for 50 Hz (50 V or 25 V).

2.13 Summary

As is customary for Type A RCDs, the rated residual current of AC-DC sensitive RCDs may also characterise the level of protection they provide. The frequency response of the tripping current must therefore always remain below the hazard

limit which applies to the relevant level of protection. Matching the frequency response characteristic closely to the corresponding limit curves can minimise undesired response by the RCDs to leakage currents at the various frequencies. In practice, however, high leakage currents frequently require a residual current operated protective device with high response current thresholds in the frequency range of the leakage currents. The level of protection specified for the rated residual current is however frequently no longer guaranteed by such a device, since its tripping current is above the hazard limit curve specified for this level of protection at particular frequencies. The current standards for Type B RCDs do not as yet contain any provisions prohibiting such jumps in protection level over the various frequencies. The upper frequency limits of residual current detection specified in these standards are also too low to ensure protection against the residual currents of most clocked electronic equipment. The German standards for Type B+ RCDs dispel certain ambiguities in respect of fire protection, at least for equipment with residual current frequencies of up to 20 kHz; however, this protective effect is not guaranteed for certain common types of equipment with higher clock frequencies. It is therefore impossible at present for system designers to ascertain on the basis of the tripping current frequency response whether the required level of protection for the relevant application is in fact achieved for all potential residual current frequencies.

Part III

Appendix

3. Appendix

3.1 Abbreviations used in the text

Abbreviation	Description
RCD	Residual current operated protective device
RCCB	Residual current operated circuit breaker without integral overcurrent protection
RCBO	Residual current operated circuit breaker with integral overcurrent protection
CBR	Circuit-breaker incorporating residual current protection
MRCD	Modular residual current operated protective device
RCM	Residual current monitor
RCMU	Residual current monitoring unit
EMC	Electromagnetic compatibility
FC	Frequency converter
PE	Protective earth
R_F	Fault resistance
I_F	Residual current

Table 2 Overview of abbreviations

3.2 Overview tables for RCDs of Type B SK/B+/NK

Type B SK	Characteristics	Comment
two-pole		The SK design is suitable for use in electrical systems in which particularly high leakage currents are to be expected in the range of the switching frequencies of the electronic equipment and in which fire protection is not required. The lower sensitivity in the upper frequency range means that undesired tripping is largely avoided. Tripping frequency response in line with DIN EN 62423 (VDE 0664-40) with extended frequency range up to 100 kHz, increased tripping threshold for frequencies >1 kHz up to 100 kHz compared to DFS 4 B NK. For systems with PV inverters, frequency converters, UPS devices etc.
DFS 4 B SK	230 Volt, AC-DC sensitive, 16-125 A, 4 module, two-pole	
FIB B SK FIC B SK	230 Volt, AC-DC sensitive, 6-32 A, 4 module, one-pole + N	
four-pole		
DFS 4 B SK DFS 4 B SK S (selective)	230/400 Volt, AC-DC sensitive, 4 module, four-pole	
DFS 4 B SK V500	500 Volt (special voltage, e.g. medical technology), AC-DC sensitive, 4 module, four-pole	
FIB B SK FIC B SK	230/400 Volt, AC-DC sensitive, 6-32 A, 6 module, three-pole + N	
DFL 8 B SK	230/400 Volt, AC-DC sensitive, 100-250 A, four-pole, mounted on mounting plate or in N7 housing	
DFL 8 B SK X	230/400 Volt, AC-DC sensitive, 100-250 A, four-pole, rated residual currents adjustable, mounted on mounting plate or in N7 housing	

Table 3 Overview of Type B SK

Type B+	Characteristics	Comment
two-pole		For use in electrical systems in which increased preventive fire protection is required (tripping threshold max. 420 mA). Tripping frequency response in line with DIN VDE 0664-400 up to 20 kHz. For systems with PV inverters, frequency converters, UPS devices etc.
DFS 4 B+	230 V, AC-DC sensitive, 16-125 A, 4 module, two-pole	
four-pole		
DFS 4 B+	230 V / 400 V, AC-DC sensitive, 16-125 A, 4 module, four-pole	
DMRCD 1B+	AC-DC sensitive, 4 module, rated residual currents adjustable, pre-alarm, 10-way display, external summation current transformer with 35-140 mm diameter	

Table 4 Overview of Type B+

Type B NK	Characteristics	Comment
two-pole		<p>For use in electrical systems in which reliable fire protection is required over a broad frequency range (tripping threshold max. 300 mA).</p> <p>Tripping frequency response in line with DIN EN 62423 (VDE 0664-40) with extended frequency range up to 100 kHz.</p> <p>For systems with PV inverters, frequency converters, UPS devices etc.</p>
DFS 4 B NK	230 Volt, AC-DC sensitive, 16–125 A, 4 module, two-pole	
FIB B NK FIC B NK	230 Volt, AC-DC sensitive, 6–32 A, 4 module, one-pole + N	
four-pole		
DFS 4 B NK DFS 4 B NK S (selective)	230/400 Volt, AC-DC sensitive, 16–125 A, 4 module, four-pole	
DFS 4 B NK V500	500 Volt (special voltage, e.g. medical technology), AC-DC sensitive, 16–125 A, 4 module, four-pole	
FIB B NK FIC B NK	230/400 Volt, AC-DC sensitive, 6–32 A, 6 module, three-pole + N	
DFL 8 B NK	230/400 Volt, AC-DC sensitive, 100–250 A, four-pole, mounted on mounting plate or in N7 housing	
DFL 8 B NK X	230/400 Volt, AC-DC sensitive, 100–250 A, four-pole, rated residual currents adjustable, mounted on mounting plate or in N7 housing	

Table 5 Overview of Type B NK

3.3 Index

A

Leakage currents.....	9, 10, 14, 15, 16, 17, 18, 19, 20, 21, 23, 46, 48, 52, 53, 54, 56, 57, 61
Reduction.....	17
stationary.....	14
transient	16
variable	15
AC-DC sensitive.....	7, 8, 45, 61, 62
	<i>see also</i> Type B
Output frequency.....	11, 46, 50, 51
Output voltage.....	13, 19, 46, 51

B

Rated residual current.....	26, 33, 42, 45, 46, 47, 49, 52, 54, 55, 56, 57
Equipment	
electronic.....	8, 52
Fire protection	26, 50, 52, 53, 54, 55, 62
Bridge connection	8
B6	8, 14

C

CBR.....	32, 35, 36, 60
Chopper frequency.....	<i>see</i> switching frequency

D

DFL8	36
DFL 8 B NK.....	62
DFL 8 B NK X.....	62
DFL 8 B SK	61
DFL 8 B SK X.....	61
DFS 4 B NK.....	61, 62
DFS 4 B NK S.....	62
DFS 4 B NK V500	62

DFS 4 B SK	61
DFS 4 B SK S	61
DFS 4 B SK V500.....	61
Residual current analysis	<i>see</i> DRCA 1
DMRCD.....	32, 36
DMRCD 1B+	61
DRCA 1.....	24
DRCM	36

E

electronic equipment	8, 52
EMC	9, 13, 60
filter	15, 16, 21, 23
Anti-interference measures.....	9

F

Fault protection.....	30, 31, 49
Residual current	9, 10, 11, 17, 25, 33, 36, 39, 42, 45, 46, 47, 49, 50, 51, 55
	<i>see also</i> DC residual current;
	<i>see also</i> AC residual current
Residual currents.....	9
Residual current operated protective device <i>see</i> RCD	
Residual current circuit-breaker.....	<i>see</i> RCCB
Effect of moisture.....	9, 11
FIB B NK.....	62
FIC B NK.....	62
Frequency converter	8, 11, 13, 14, 15, 16, 17, 18, 19, 20, 21, 23, 25, 33, 46, 51, 60
FC	60

G

Total current.....	14
DC residual current	
smooth	8, 11

I

I _F	60
Insulation fault	9, 10, 11

M

Machine frequency.....	see output frequency
Motor frequency	see output frequency
Motor supply cable long	15, 23
MRCDC	32, 35, 36, 60

N

Mains frequency.....	10, 42, 45, 46
Mains voltage	
Distortions in.....	14
Standards and guidelines	
BGI 530.....	34
BGI 608	27
BGI 665	34
BGI 867.....	34
BGI 5087.....	34
DIN VDE 0100-530	17
VDE 0100-482	34
VDE 0100-530.....	35
VDE 0100 Part 530.....	26
VDE 0100 Part 704.....	32
VDE 0100 Part 712	29
VDE 0100 Part 722	32
VDE 0100 Part 723	33
VDE 0113-1	31
VDE 0113-1 (EN 60204-1).....	31
VDE 0160 / EN 50178	25
VdS 2033 / 2046 / 2067	34
VdS 3501	33

O

Harmonic component	11, 13, 15, 19, 46, 50, 51
--------------------------	----------------------------

P

PE	60
Personal protection	42, 47, 49, 52

R

RCBO / RCCB	35, 55, 60
RCD.....	8, 33, 36, 41, 45, 46, 47, 48, 49, 50, 56, 57, 60
RCM / RCMU	36, 60
Resonance frequency	15, 16, 20, 21, 22
RF	60

S

Switching frequency.....	11, 15, 16, 17, 20, 21, 22, 24
Effect of dirt	9
Protection level	41, 42, 45, 46, 47, 50, 52, 53, 54, 57
Six-pulse bridge rectifier.....	11, 50

T

Elementary frequency.....	see switching frequency
Type A	42, 55, 56
Type AC.....	8
Type B	46, 47, 50, 55, 56, 57, 61, 62
DFL 8 B	17, 61, 62
DFS 4 B	17, 52, 53, 54, 61, 62

V

VDE Guidelines.....	25, 31
.....	see also Standards and guidelines

W

AC residual current.....	9, 42
Inverter	8, 16, 46, 52

Z

additional protection.....	42
Intermediate circuit capacitor.....	11

Doepke

Doepke UK Ltd
3 Bentley Way
Royal Oak Ind. Estate
Daventry, NN11 8QH

Tel.: 01628 829 133
Fax: 01327 878 749
Email: sales@doepke.co.uk
www.doepke.co.uk

