

Type B residual current devices (Type B RCCBs)

Application and Installation
Guide for Electrical Engineers

April 2023

www — doepke.co.uk



Liability

All information contained in this document belonging to Doepke Schaltgeräte GmbH (Doepke UK Ltd) is protected by copyright. The reproduction and processing, altering and/or transfer against payment of such information is permissible only with the express written approval of Doepke GmbH. This information is provided solely as customer information and does not constitute a binding guarantee or undertaking. It is subject to technical or commercial changes at any time. For specific applications please contact Doepke Sales Support.

The use of this document is solely at your own discretion. Doepke accepts no liability for any loss or damage arising from the use of this document, in particular breakdown of operations, loss of profit, loss of information and data, or consequential damage caused by a defect, except in cases of compulsory liability, e.g. as provided for by the German or UK Product Liability Law (as appropriate), or in cases of premeditation, gross negligence or because of infringement of fundamental contractual obligations. Compensation for infringement of fundamental contractual obligations shall, however, be limited to foreseeable damage typical of the contract, provided there is no premeditation or gross negligence. Copyright © Doepke Schaltgeräte GmbH / Doepke UK Ltd

Technical Information

April 2023

Contents

1. Why 'AC-DC sensitive'?

1.1.	AC-DC sensitive residual current devices and frequency converters	page 6
1.2.	Residual currents or leakage currents?	page 7
1.2.1.	Residual currents	page 7
1.2.2.	Leakage currents	page 7
1.3.	Systems with frequency converters	page 8
1.3.1.	Insulation fault at the frequency converter input	page 8
1.3.2.	Insulation fault at the intermediate circuit capacitor	page 8
1.3.3.	Fault between frequency converter and motor	page 9
1.3.4.	Single-phase operated frequency converter	page 10
1.4.	General observation on leakage currents	page 11
1.4.1.	Stationary leakage currents	page 12
1.4.2.	Use of single-phase operated frequency converters	page 13
1.4.3.	Variable leakage currents	page 13
1.4.4.	Transient leakage currents	page 14
1.5.	Countermeasures	page 15
1.5.1.	Reduction of stationary leakage currents	page 15
1.5.2.	Reduction of variable leakage currents	page 16
1.5.3.	Additional possibilities for reducing stationary and variable leakage currents	page 16
1.5.4.	Reduction of transient leakage currents when switching an electrical system with electronic equipment on and off	page 17
1.5.5.	Avoiding natural oscillation (resonance) by an EMC filter	page 18
1.5.6.	Inductive leakage currents	page 19
1.5.7.	Changes to existing electrical systems	page 19
1.6.	Integrated EMC filters	page 19
1.7.	Measurement of leakage currents	page 20
1.8.	AC-DC sensitive residual current protection	page 21
1.8.1.	Use as prescribed	page 21
1.8.2.	Frequency controlled electric equipment at construction sites	page 22
1.8.3.	Use of RCDs with photovoltaics	page 24
1.8.4.	RCDs in electrical machinery	page 27
1.8.5.	Further applications	page 27
1.8.6.	Additional guidelines requiring Type B RCDs:	page 28
1.9.	Distribution of electric circuits	page 29
1.10.	Protection via automatic disconnection of the power supply	page 30
1.11.	Basic circuits for electronic equipment	page 31
1.12.	Generation of a smooth DC residual current from individual currents	page 33

2. Tripping current frequency response and level of protection

2.1.	Protection by Type A RCDs which are sensitive to pulsating currents	page 36
2.2.	Protection by Type FRCDs	page 36
2.3.	Protection when charging electric vehicles using DFS4 EV	page 37
2.4.	Protection when using the MI design	page 37
2.5.	Implications of the frequency response for the level of protection	page 38
2.6.	Protection by Type B RCDs with extended frequency range	page 39
2.7.	Requirements for the tripping current level	page 40
2.8.	Requirements applicable to the upper frequency limit of residual current detection	page 43
2.9.	Frequency response for a consistent level of protection	page 44
2.10.	Frequency response with a jump in protection level' in systems with high leakage currents	page 45
2.11.	Requirements laid down in standards in relation to the tripping current frequency response	page 47
2.12.	Earth resistances for fault protection	page 48
2.13.	Summary	page 48

3. Appendix

3.1.	Abbreviations used in the text	page 50
3.2.	Overview tables for RCDs of Type B SK/B+/NK	page 51
3.3.	RCD tripping limit values	page 52
3.4.	Index	page 54

1. Why 'AC-DC sensitive'?

1.1. AC-DC sensitive residual current devices and frequency converters

Multi-phase operated electronic equipment such as frequency converters (FC) or inverters may produce a smooth DC residual current in the event of a fault, as shown in Fig. 1.

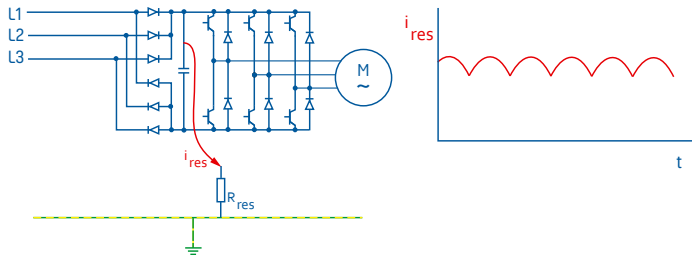

Fig. 1: Production of an almost smooth DC residual current (simplified representation of a frequency converter with B6 bridge rectifier, intermediate circuit capacitor, output stage and motor)

The smooth DC residual current¹ that is generated by the B6 connection at the frequency converter input would not cause conventional Type A or Type AC RCDs to trip.

This is because the magnetisation in the summation current transformer does not vary over time and without this there can be no inductive transfer of energy to the tripping relay.

Depending on how high it is, the DC residual current instead results in pre-magnetisation of the transformer core, thus increasing the tripping threshold for any additional AC residual currents or even preventing tripping altogether.

¹ Formation of the DC residual current from the three individual currents of the line conductors L1, L2 and L3 is shown in greater detail in Fig. 5 (p. 9).

1.2. Residual currents or leakage currents?

1.2.1. Residual currents

Residual currents are predominantly resistive and are created by insulation faults between voltage-carrying parts and earth, for example as a result of dirt and moisture in a device. Another example would be the flow of current to earth which occurs when an individual comes into direct contact with an active conductor in the network (see Fig. 2).

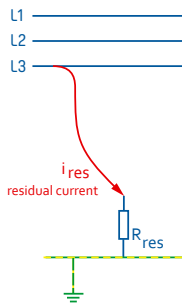

Fig. 2: AC residual current

1.2.2. Leakage currents

Leakage currents are usually capacitive currents which occur under operating conditions and which flow to earth, for example through capacitors in EMC filters (EMC: electromagnetic compatibility) that are being used as anti-interference measures or due to the capacitance of long shielded cables (see Fig. 3).

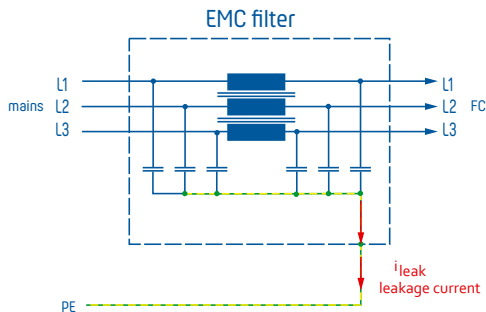

Fig. 3: Capacitive leakage current (simplified representation of an EMC filter)

Both residual currents and leakage currents can simultaneously include multiple frequency components which differ significantly from the mains frequency of 50 Hz, depending on the application and the electrical system. RCDs cannot distinguish between residual currents and leakage currents, which are therefore evaluated identically. For example, tripping may take place if the sum of all the leakage currents flowing exceeds the tripping threshold for the residual current operated protective device, even though there is no fault (residual current) in the electrical system.

1.3. — Systems with frequency converters

1.3.1. — Insulation fault at the frequency converter input

An earth fault is present at the frequency converter input. A purely sinusoidal residual current of 50 Hz is flowing. If this residual current is high enough, the residual current operated protective device will be reliably tripped.

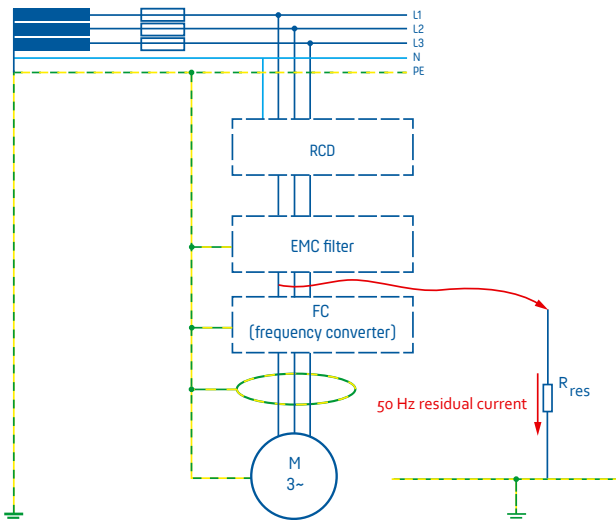

Fig. 4: Residual current of 50 Hz

1.3.2. — Insulation fault at the intermediate circuit capacitor

An insulation fault occurs between the positive terminal of the intermediate circuit capacitor and the frequency converter housing. This fault may be caused, for example, by dirt and exposure to moisture.

An almost smooth DC residual current is flowing. If Type B RCDs are used, reliable tripping is guaranteed if the DC residual current is high enough.

Note — In many frequency converters, the two poles of the intermediate circuit ($DC+$, $DC-$) are routed to the exterior in the form of two terminals, e.g. for energy recovery. They are therefore particularly vulnerable to dirt and/or moisture.

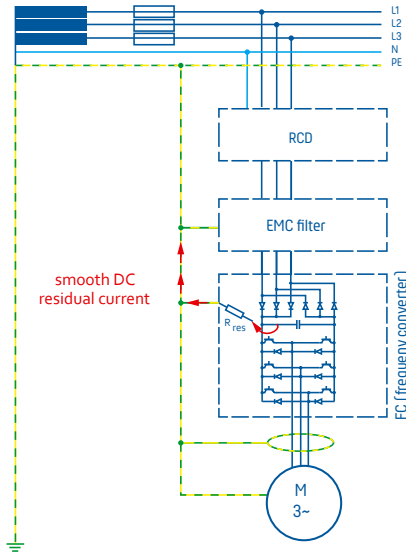

Fig. 5: DC residual current

1.3.3. Fault between frequency converter and motor

The motor is for example operated at an output frequency (also referred to as machine or motor frequency) of 10 Hz. The switching frequency (also referred to as the chopper or elementary frequency) of the frequency converter is for instance 8 kHz. A residual current comprising an extremely large number of frequency components is now flowing. In addition to the output frequency of 10 Hz with a lower amplitude, the switching frequency of the frequency converter at 8 kHz and its harmonic components of 16 kHz, 24 kHz, 32 kHz etc. are also present as significant components. A 150 Hz component with low amplitude, generated by the input-side six-pulse bridge rectifier of the frequency converter, is also present.

Correct tripping is generally also guaranteed in this case when using Type B RCDs. In exceptional cases (depending on the EMC filter measures used), the higher-frequency components in the residual current may not flow back exclusively via the star point – mainly due to the filter capacitances – meaning that they are not fully detected by the residual current operated protective device. If necessary, a fault should be simulated using a suitable test device in order to determine whether correct tripping is guaranteed.

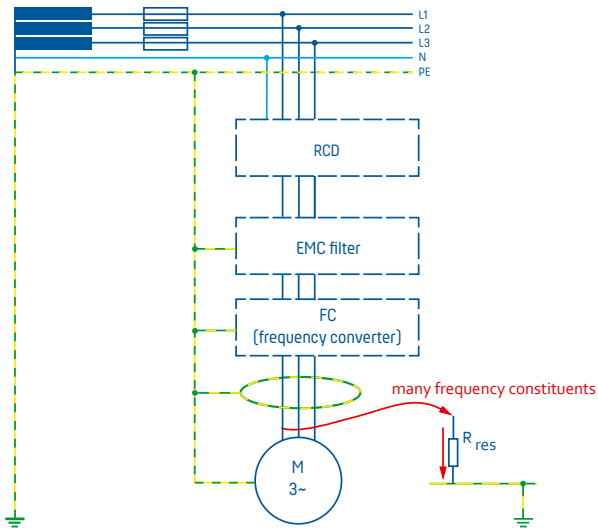

Fig. 6: Residual current with mixed frequencies

Note — Alternatively (Germany VDE Standards only), a Type B+ residual current operated protective device can also be used for the faults cited as examples in Section 1.3.

1.3.4. Single-phase operated frequency converter

If single-phase operated frequency converters are used in an electrical system, a Type F residual current operated protective device is generally sufficient. In the event of a fault, either a sinusoidal AC residual current or a pulsating DC residual current resulting from the rated frequency (50 Hz) occurs depending on the fault point. Addi-

tional spectral components of the output frequency and the switching frequency with harmonic components are generally present in the residual current. Smooth DC residual currents cannot generally occur.

However, specially designed single-phase operated frequency converters contain a PFC stage or a boost converter in the intermediate circuit in order to raise the intermediate circuit voltage so that electric motors designed for a rated voltage of 400 V can also be connected. Nevertheless, if frequency converters of this type are used, residual currents with a high DC component may occur in the event of a fault and these will no longer be detected by Type A or F RCDs. Maximum smooth DC values for Type A or F RCDs are given in Table 7 / Page 53. Type B or B+ RCDs must be used if these values are exceeded. Only Type B or B+ RCDs may be used in this case. The manufacturer of the frequency converter is obliged to provide information on this topic in the relevant documentation.

For further information, see the table with basic wiring diagram 9 in the section entitled 'Basic circuits for electronic equipment and the potential residual currents which may result'.

1.4. — General observation on leakage currents

A distinction is made between stationary, variable and transient leakage currents. The example of a system with an asynchronous motor which is operated with a frequency converter will be used again for clarification purposes.

To ensure compliance with the relevant EMC regulations, the frequency converter may only be operated using an upstream EMC filter, which may also be integrated into the frequency converter itself. Since the pulse-width modulated output voltage of the frequency converter has a very steep edge and therefore contains harmonic components of high amplitudes and frequencies, the motor (again, in order to comply with EMC regulations) may only be connected to the frequency converter using a shielded cable.

The EMC tests define the length of the cable between the frequency inverter and the motor. Increasing the length of cable can significantly increase the leakage current. Refer to the manufacture's installation instructions for advice.

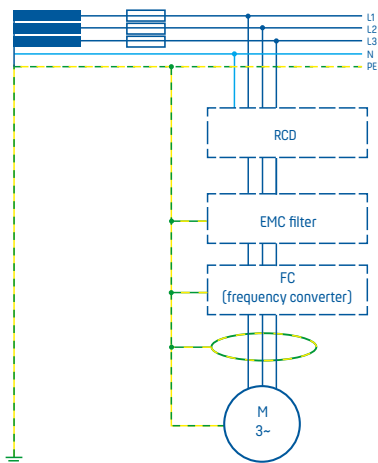

Fig. 7: Connection example with an asynchronous motor

1.4.1. Stationary leakage currents

In its simplest design, the EMC filter consists of LC low-pass filters whose capacitors are connected to the protective conductor using a star configuration. In an ideal network with a strictly sinusoidal voltage, the sum of all capacitive currents through these capacitors is zero. However, as a result of the relatively strong distortions in the mains voltage, there is – in practice – a capacitive total current which is not equal to zero. This flows continuously via the protective conductor and is therefore referred to as a stationary leakage current. Significant leakage currents are also generated through the commutation of the B6 bridge connection at the frequency converter input and the commutation of the internal Y capacitors from the intermediate circuit to the PE. If three-phase operated frequency converters are used, a 150 Hz component which depends on the size of the Y capacitors is mainly present. The 150 Hz leakage current generated in this way cannot generally be reduced, even by using additional filter measures. When using RCDs with $I_{\Delta n} = 30 \text{ mA}$, this leakage current can therefore result in a high preload. Some frequency converter manufacturers indicate that the operation of frequency converters of this kind with an upstream residual current operated protective device may result in undesired tripping. The stationary leakage current is also present if the motor is not running (controller lock of the frequency converter)

and typically has frequency components of 100 Hz to 1 kHz and frequency components in the range of the resonant frequency of the EMC filter (typically in the range from 2 to 4 kHz). Very cheap and simple EMC filters with low inductances and large capacitors produce high leakage currents and can result in the undesired tripping of the residual current operated protective device.

1.4.2. — Use of single-phase operated frequency converters

Single-phase operated frequency converters often have an integrated EMC filter. The filter capacitors in this filter are connected from L to PE and N to PE. This results in significant 50 Hz leakage currents. If several frequency converters are used, care must be taken to ensure that they are distributed as uniformly as possible across the three line conductors L1, L2 and L3 in order to compensate for the leakage currents and avoid tripping by the residual current operated protective device.

1.4.3. — Variable leakage currents

If the speed of the motor is regulated by the frequency converter, additional frequency components above 1 kHz will occur in the total leakage current. In particular, the switching frequency of the frequency converter (typical values: 2, 4, 8, 16 kHz) and the associated harmonic components are present at a very high amplitude. A long motor cable with an earthed shield has the same effect as a capacitor which is connected to earth and conducts currents at a corresponding frequency to earth together with their harmonic components. In addition, the frequency components in the range of the resonant frequency of the EMC filter can increase sharply if the switching frequency of the frequency converter is approximately the same as or is a multiple of the resonant frequency of the EMC filter. The EMC filter is stimulated to oscillation by the switching frequency of the frequency converter and can generate very high leakage currents in the range of the resonant frequency. Even if the frequency converter is set to a very high switching frequency (e.g. 16 kHz), at low output frequencies (including when the motor is started up and shut down) the frequency converter may significantly reduce its switching frequency automatically in line with the modified modulation method. In a worst-case scenario, the reduced switching frequency may be approximately the same as or a multiple of the resonant frequency of the EMC filter. This causes the leakage current to rise sharply and significantly increases the risk of a residual current operated protective device tripping accidentally.

If the motor speed is constant, stationary and variable leakage currents are almost periodic. RCDs respond to these leakage currents with a switch-off if the currents exceed the response threshold for the residual current operated protective device at the relevant frequency. Changes in speed also bring about changes to the variable leakage currents in terms of both frequency spectrum and amplitude, and may potentially result in tripping.

1.4.4. ——— Transient leakage currents

Note ——— *The filters described in this section are generally available as accessories from the manufacturers of the electronic equipment (frequency converters, inverters etc.). These manufacturers will also be able to provide further technical details if necessary.*

In the event of a switch-off, voltage peaks occur in the network due to inductances in the current paths, and contain very high frequency components due to the steep rising edges. In the event of a switch-on at an unfavourable mains voltage phase angle, the mains voltage spectrum also contains high-frequency components for short periods owing to the rapid rise in voltage. These high-frequency voltage components divert transient currents to earth via the above-mentioned capacitances of the EMC protective measures and this can cause accidental tripping of RCDs. If the mains voltage is switched on using non-snap action switches, the three line conductors will be connected at staggered intervals depending on the switching speed. If voltage is not being carried by all three conductors, an increased leakage current will flow to earth via the filter capacitors of the EMC filter from the conductors which have already been connected.

Nuisance tripping due to transient leakage currents can in many cases be avoided by using RCDs with a response delay. In order to avoid any inadmissible impairment of the protective function, the response delay is not allowed to exceed certain maximum values. This means that RCDs cannot be arbitrarily 'immunised' against transient leakage currents either. The RCDs of the DFS 4 B and DFL 8 B series have a response delay of this kind. However, if the duration of the transient leakage currents exceeds the maximum permissible response delay prescribed in the regulations, tripping will nevertheless occur if the currents are sufficiently high.

1.5. Countermeasures

As made clear in the above chapters, an improvement in the rate of nuisance tripping by RCDs as a result of leakage currents has an adverse impact on protective function in most cases. The following measures are therefore always recommended to keep leakage currents as small as possible.

In line with paragraph 531.2.3 of DIN VDE 0100-530 and BS7671 531.3.2 (Unwanted tripping), the electrical system must be designed in such a way that the leakage current does not exceed 0.3 times the rated residual current of the residual current operated protective device.

Filter measures (both internal filter components and filters installed upstream or downstream of the frequency converter) significantly influence the flow of leakage currents and residual currents in an electrical system. Depending on the design of the filter measures, higher-frequency currents can flow through the Y capacitors in such a way that they can no longer be detected by upstream RCDs (which is undoubtedly beneficial in the case of undesired leakage currents). In order to ensure that higher-frequency residual currents (e.g. at the switching frequency of the frequency converter) are still detected by an upstream residual current operated protective device, tests should be carried out with artificially generated faults (e.g. using suitable test devices) on the output side of the frequency converter, where necessary, in order to guarantee tripping in the event of a fault.

1.5.1. Reduction of stationary leakage currents

Many frequency converter manufacturers now offer 'low leakage current' EMC filters. The design of these types of filter means that the leakage currents are significantly lower than in standard filters. The manufacturer's specifications concerning the maximum permitted length of the shielded motor supply cable should be observed. The E6 EMC filter series from the manufacturer 'KEB Antriebstechnik' is a good example of this type of device. The filters in the E6 series only generate very low leakage currents and generally allow the use of Type B or B+ RCDs with a rated residual current of 30 mA.

A four-wire filter can be used in electric networks where there is a neutral conductor. This filter type offers the lowest leakage currents: The main component of the leakage currents is discharged via the neutral conductor.

Additional measures should be taken to ensure that the mains voltage remains as undistorted as possible.

A single-phase consumer such as a single-phase operated frequency converter should not under any circumstances be connected to the neutral conductor at the output of a three-phase EMC filter (without neutral conductor connection). The asymmetric loading of the filter further increases the leakage currents, greatly impairing the filter effect and meaning that the permitted limits for compliance with the EMC regulations are exceeded by far.

Note — *Servo drive systems may prohibit or restrict the use of output filters. High leakage currents can flow due to the sudden changes in motor speed and direction, required for accurate positioning. To avoid unwanted tripping, the manufacturer's recommendations should be followed with regard to RCD sensitivity.*

If several single-phase operated frequency converters are used, they should be distributed uniformly across all line conductors in order to compensate for the leakage currents.

1.5.2. — **Reduction of variable leakage currents**

The shielded motor supply cable should be as short as possible, with the internal conductors arranged symmetrically and with low impedance.

Sinusoidal filters, EMC sinusoidal filters, du/dt filters or output chokes should be installed directly downstream of the frequency converter output (upstream of the motor supply cable). By reducing the rising edge of the frequency converter output voltage, they significantly reduce leakage currents above 1 kHz on the cable to the motor. Particularly low leakage currents are achieved if a du/dt filter is used.

By minimising the rise time of the output voltage, output filters also reduce noise emissions as well as motor bearing currents and high inductance voltages at the motor windings.

If several frequency converters with their own (integrated) EMC filter are used, a shared upstream four-wire filter can be used in addition as a means of significantly reducing the variable leakage currents.

1.5.3. — **Additional possibilities for reducing stationary and variable leakage currents**

Mains chokes which are placed upstream of the EMC filter reduce the current ripple and the associated harmonic components, and also increase the lifetime of components in the frequency converter.

In electrical systems with several frequency converters, a collective filter should be used instead of having individual EMC filters for each frequency converter. The leakage currents of the individual EMC filters are added together. The sum of the leakage currents from all the individual filters is generally larger than the leakage current from a larger shared filter. The information provided by the filter manufacturer concerning the maximum permitted lengths of shielded motor supply cables should be observed.

If several frequency converters are used in an electrical system, care should be taken to avoid starting them up at the same time. If a controller enable is issued for several frequency converters at once, this may temporarily result in high leakage currents which are added together, potentially resulting in undesired tripping.

1.5.4. — Reduction of transient leakage currents when switching an electrical system with electronic equipment on and off

As mentioned above, compliance with the EMC regulations means that filters must be used if electronic equipment is installed. For example, in the case of a three-wire standard EMC filter, these filters contain a star connection of three capacitors to earth. Most RCDs contain a positively linked switching mechanism. The closing and opening time of the individual contacts depends on the operating speed of the toggle. Under certain circumstances, this can result in a time difference of 10 to 40 ms between the total operating time of all the contacts. The star point of the three capacitors is no longer balanced during this time. A significant capacitive leakage current may flow via the protective conductor, causing the residual current operated protective device to trip immediately. Connection and disconnection should therefore only be performed using an additional fast-acting switching device (e.g. a disconnecter with snap-action operation or an all-pole switching contactor) rather than the residual current operated protective device itself. In electrical systems with a very large number of frequency converters, tripping may occur in exceptional cases, particularly during switch-on, even if a fast-acting switching device is used. In such cases, very high leakage currents flow for a period which exceeds the maximum permissible disconnection time as a result of the uncharged filter capacitors. A collective EMC filter for several frequency converters may also significantly reduce the high switch-on leakage current.

Example — The resonant frequency of the EMC filter is 2.1 kHz. If a switching frequency of 2 kHz were chosen for the frequency converter, it would be very close to the resonant frequency and could result in very high leakage currents under certain circumstances. Even a switching frequency of 4 kHz could still lead to high leakage currents, since this is almost twice the resonant frequency. Higher switching frequencies and in particular non-multiples of the resonant frequency (e.g. 6 kHz, or preferably 7 kHz) will make the EMC filter less likely to oscillate, in turn reducing the high leakage currents associated with this. Further details regarding the resonant frequency of the EMC filter and the potential deactivation of automatic changes to the switching frequency of a frequency converter at low output frequencies should be requested from the manufacturers of the equipment where necessary.

1.5.5. — Avoiding natural oscillation (resonance) by an EMC filter

As a rule, different switching frequencies (choppers) can be selected for electronic equipment such as frequency converters. In a worst-case scenario (e.g. a long shielded motor supply cable), the switching frequency may result in the oscillation of an upstream EMC filter and excessively high leakage currents, which then lead to tripping of the residual current operated protective device. The switching frequency of the frequency converter must be changed in such cases. In addition, the maximum permitted length prescribed by the frequency converter or filter manufacturer for the shielded motor supply cable must be observed.

Note — These integrated filters often impose a maximum length of just 5 to 10 m on the shielded motor supply cable. The conformity declarations specified in the frequency converter operating instructions in respect of the EMC guidelines (e.g. EN 55011, Class A, B) are generally only valid for these relatively short cable lengths. Cable lengths of 50 to 100 m are often also specified. However, such cable lengths do not generally relate to EMC conformity, but to the maximum permitted capacitive load (capacitance of the shielded motor supply cable) which can be supported without difficulty by the frequency converter's output stage.

There is an increased risk of undesired tripping if the switching frequency of the frequency converter is approximately equal to or is a multiple of the resonant frequency of the EMC filter. Many frequency converters reduce their switching frequency automatically at low output frequencies (typically below approximately 20 to 30 Hz, and also when the motor is started up and shut down).

Higher switching frequencies (including higher-order multiples of the resonant frequency) generally minimise the likelihood of oscillation in the EMC filter.

1.5.6. — Inductive leakage currents

As mentioned above, leakage currents are generally capacitive currents. However, inductive leakage currents are not unusual, and are particularly likely to occur in electrical systems with very high currents. They therefore tend to occur in the lower frequency range.

Example — *Electrical system with three-phase operated frequency converter and EMC input filter and motor with conventional shielded four-core motor supply cable (U, V, W, N/PE) with a length of approx. 50 m. The machine frequency is 20 Hz and the motor current per phase is approx. 200 A. As a result of the asymmetric internal design of the four-core motor cable, an inductive injected leakage current of several hundred mA may occur at a frequency of 20 Hz in the N/PE current path. Therefore, shielded motor supply cables that have the inner conductors arranged symmetrically and with low impedance should therefore be used wherever possible. This significantly reduces both inductive and capacitive leakage currents.*

1.5.7. — Changes to existing electrical systems

If changes are made to an existing electrical system which has already been checked for EMC purposes (for example, if changes are made to the filter design or to the switching frequency of a frequency converter), EMC-related measurements must generally be repeated to ensure that the system still complies with the relevant applicable EMC guidelines. Checks should also be carried out to ascertain whether reliable tripping of the residual current operated protective device is still guaranteed in the event of faults on the output side of the frequency converter.

1.6. — Integrated EMC filters

Many frequency converters already feature an internal EMC input filter, which means there is no need for an external one.

Longer supply cables result in magnetic saturation of the EMC filter choke as a result of the increase in asymmetric capacitive currents. The consequence of this is extremely high leakage currents and filter resonance. A saturated filter choke renders the filter ineffective, meaning that the permitted limit values of the relevant EMC

guidelines are exceeded by far and the frequency converter becomes a frequently unnoticed source of significant interference for other equipment.

If a frequency converter with an integrated EMC filter and long shielded motor supply cable (> 10 m) is used, the integrated filter must be deactivated wherever possible and an external EMC filter installed which is suitable for use with long motor supply cables. It may be necessary to carry out EMC measurements on the entire electrical system in order to determine which filter is suitable.

1.7. — Measurement of leakage currents

In order to allow the reliable and uninterrupted operation of an electrical system with a residual current operated protective device, it should be ensured that there is no risk of undesired tripping due to high leakage currents in all the various operating states of the electronic equipment.

With this in mind, it is useful to measure the leakage current or residual current, which is also detected by the residual current operated protective device used. In functional terms, the measuring instrument used for this purpose should be almost identical to the residual current operated protective device in terms of the frequency range across which it can measure residual currents and the various frequencies which it can evaluate.

A suitable summation current transformer should preferably be positioned in such a way that it is subject to the same flow from the conductors to be monitored as the residual current operated protective device used. The instrument transformer is connected to a measuring unit for signal processing purposes, which in turn is connected to a notebook or PC. A measuring system of this kind is implemented using the DRCA 1 residual current analysis system. The software supplied is used to carry out a wide range of measurements (time-based representation of residual current, frequency analysis, frequency-dependent evaluations, recording of very brief signals, long-term measurements etc.) and store the results.

All of the system's operating states (such as switching on and off, start-up and shut-down of individual and (where applicable) multiple frequency converters, drive mode at various machine frequencies etc.) should be taken into account and measured in order to determine the maximum critical leakage current. These results can be used as a basis for any measures required to guarantee the

uninterrupted operation of the electrical system (altering the switching frequency of the frequency converter, using four-wire filters etc.).

Note — Many of the residual current test devices currently on the market are not suitable for measurements of this kind. They can generally only be used to measure mains frequency currents (50/60 Hz). Even broad-band measuring clamp-on probes generally only provide for a frequency range of up to max. 1 kHz and are often only suitable for measuring currents in the high ampere range. They are incapable of detecting leakage currents adequately in either the lower or the higher frequency range, and distort the measuring results: Use DRCA 1 to provide accurate results.

1.8. AC-DC sensitive residual current protection

1.8.1. Use as prescribed

If smooth DC residual currents (no zero point contact) can be expected to occur in electrical systems owing to the presence of particular electronic equipment, the use of an AC-DC sensitive residual current operated protective device is already prescribed in many cases by the relevant standards. This applies e.g. to three-phase operated frequency converters, which use a six or twelve-pulse bridge connection on the input side in order to rectify the mains voltage (see Fig. 8).

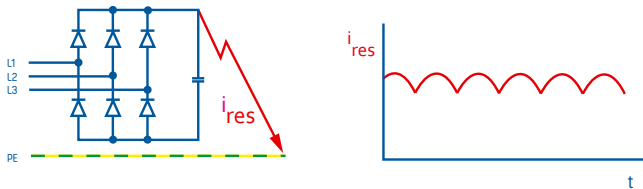

Fig. 8: Six-pulse bridge connection (three-phase AC bridge connection)

VDE 0100 Part 530 & BS7671: Low-voltage electrical installations – Selection and erection of electrical equipment – Switchgear and control gear

Section 531.3.3 lists the various types of RCD (AC, A, F, B) and their tripping behaviour in relation to DC residual currents and AC residual currents \neq rated frequency. Appendix A shows several types of residual current. This includes currents which only permit the use of Type B RCDs.

Type B RCDs (in Germany: Type B+ also) must be used if the electronic equipment requiring protection is capable of generating a smooth DC residual current in the event of a fault. This also applies to fixed-connection electronic equipment if a residual current operated protective device is nevertheless required (e.g. in the TT system). RCDs with a rated residual current of no more than 300 mA must be used for fire protection.

VDE 0160 / EN 50178: Electronic equipment for use in power installations

In line with Sections 5.2.11.2 and 5.3.2.3, Type B RCDs must be used to provide protection against direct and indirect contact if the electronic equipment within an electrical system is capable of producing a smooth DC residual current in the event of a fault

Note — *As mentioned above, Type A RCDs are not suitable for detecting smooth DC residual currents, since they result in pre-magnetisation of the summation current transformer and therefore significantly impair functionality. Based on the relevant product standards, the maximum load which may be applied to Type A RCDs in the event of a fault is 6 mA DC, regardless of their rated residual current.*

1.8.2. — Frequency controlled electric equipment at construction sites

Note — *The following list of applications for AC-DC sensitive residual current operated protective devices is only provided as an example and is not exhaustive. The installer of any electrical system must take the protective measures appropriate for this system as stipulated by the currently applicable provisions.*

DGUV* Information 203-006 [previously BGI 608]:**
Selection and operation of electrical installations and equipment on construction and installation sites; VDE 0100 Part 704:
Low voltage electrical installations – Requirements for special installations or locations – Construction and demolition site installations

Before connecting frequency-controlled electric equipment to a building-site distribution board, checks should be carried out to ascertain whether the integrated residual current operated protective device is suitable for this equipment. If smooth DC residual currents are to be expected in the event of a fault, the equipment may only be connected if a Type B or B+ residual current operated protective device is present. If temperatures below -5°C could occur, the equipment must be suitable for temperatures down to -25°C .

- Electrical circuits that are used to supply sockets up to 32 A and hand-held electric equipment up to 32 A (fixed connection or plug connection) must be protected by using RCDs with a rated residual current of ≤ 30 mA.
- Three-phase sockets up to 63 A must be protected with a Type B RCD.
- Three-phase sockets above 63 A must be protected by using an RCD with a rated residual current ≤ 500 mA.

Protective measures when operating frequency-controlled electric equipment on construction sites:

Multi-phase operated electric equipment with frequency converters (e.g. cranes, lifts, welding converters) may only be operated using Type B or B+ RCDs, since smooth DC residual currents may occur in the event of a fault. Alternatively, such equipment may be connected via an isolating transformer or a fixed connection.

Single-phase operated electric equipment with frequency converters (e.g. compactors, hammer drills) generate a residual current mix consisting of low-frequency and high-frequency components and a high 50 Hz component in the event of a fault. Smooth DC residual currents do not normally occur (check with the manufacturer).

Equipment of this kind does not therefore need to be operated using Type B or B+ RCDs. The use of Type F RCDs is recommended if smooth DC is < 10 mA.

In order to avoid undesired tripping of RCDs, only equipment which produces the lowest level of leakage currents possible is recommended for use.

* DGUV: German Statutory Accident Insurance Association (Deutsche Gesetzliche Unfallversicherung, DGUV)

** BGI: Insurance Association Information (Berufsgenossenschaftliche Informationen)

In special cases, a building-site distribution board with Type B RCDs, intended inter alia for the connection of a construction crane with a multi-phase frequency converter, may be connected to an existing electrical system in which only Type A RCDs are permanently installed. A further example would be the connection of a building-site distribution board with Type B RCDs to an unknown electrical system with unknown protective devices. However, this arrangement (series connection) of RCDs is not permitted under DIN VDE 0100-530.

The use of AC-DC sensitive residual current circuit-breakers (MI design) with the designation DFS 4 B SK MI or DFS 4 B+ MI can provide a solution to such problems. When Type B or B+ AC-DC sensitive residual current circuit-breakers of this kind are used, tripping in response to smooth DC residual currents takes place below 6 mA, meaning that the functionality of upstream Type A or F RCDs is not impaired by unduly high smooth DC residual currents and they are therefore protected. Further information on this topic can be found in Section 2.4 'Protection when using AC-DC sensitive residual current circuit-breakers (MI design)' in Part II of this brochure.

1.8.3. — Use of RCDs with photovoltaics

VDE 0100 /BS7671 Part 712: Low-voltage electrical installations – Requirements for special installations or locations – Photovoltaic (PV) systems

According to Section 712.531.3.5.1, Type B RCDs must be installed to protect the PV AC supply circuit.

If the electrical system is designed in such a way as to provide for simple separation between the inverter and the residual current operated protective device (separate transformer with isolated coils or use of an inverter with transformer), a Type A residual current operated protective device may be sufficient.

If the inverter manufacturer has provided written confirmation that no smooth DC residual currents can occur as a result of the use of their PV inverter, a Type A residual current operated protective device may also be sufficient.

Statements by the PV inverter manufacturer claiming that a residual current operated protective device is integrated into the inverter must however be evaluated critically. There is a high chance that an RCMU (Residual Current Monitoring Unit) – incorrectly labelled as an RCD – may instead have been integrated in line with VDE V 0126-1-1 or be present as part of an external automatic switch-

ing point. However, an RCMU cannot serve as a replacement for a residual current operated protective device, and merely increases the level of protection if the 'double or reinforced insulation' protective measure that is required on the DC side of a PV system should fail. Therefore, it merely monitors faults on the DC side and switches the PV inverter off if necessary without achieving electrical isolation. What is more, an RCMU does not provide 'additional protection' in line with DIN VDE 0100-410 / BS7671 - 411.1; see note to clause.

Measurements carried out on PV power supply systems with transformerless inverters using various switching technologies have shown that residual currents with a high direct component (> 6 mA) do indeed occur throughout the entire electrical system in the event of faults on the DC side. The PV generator voltage and the level of the fault and loop resistance determine how high this component is. A galvanic coupling is established by the transformerless inverter between the DC and AC sides, which is only made possible by the flow of a DC residual current throughout the entire PV system. These residual currents may result in the pre-magnetisation of the summation current transformer of a Type A residual current operated protective device, significantly impairing its functionality.

Further guidelines

In order to comply with the switch-off conditions for overcurrent protective devices in the event of an earth fault, the short-circuit current must be sufficiently high. It may not be possible to meet this requirement in the case of generation systems with inverters. Therefore, it may still be necessary to use RCDs in a TN system.

In certain electrical systems, RCDs are necessary regardless of the supply system (e.g. in agricultural premises in line with VDE 0100 / BS7671 - 705.411.1).

A risk assessment should always be carried out, in particular with regard to fire protection (VDE 0100 / BS7671 - 532.1).

Section 4.4.4.3 of the technical guidelines VdS 3145 'Photovoltaic systems' recommends the use of RCDs as a precautionary measure for fire protection reasons.

For safety reasons, regional network operators may enforce the use of RCDs for fault protection regardless of the supply system.

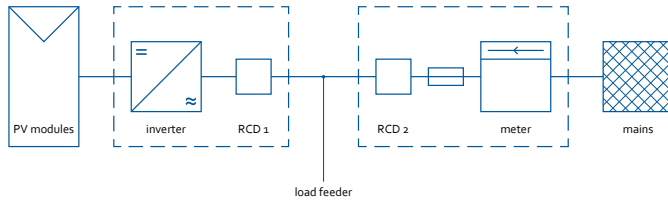

Fig. 9: Example of a system with a PV power supply system (Germany).
Note UK Installations*

		RCD 1		RCD 2	
		without feeder	with feeder ²⁾	without feeder	with feeder ²⁾
inverter protection class I without switching point/RCMU	inverter without transformer	-	type B ¹⁾	type B ¹⁾	type B ¹⁾
	inverter with transformer	-	-	type A	type A
inverter protection class I with switching point/RCMU	inverter without transformer	-	-	type B	type B
	inverter with transformer	-	-	type A	type A
inverter protection class II without switching point/RCMU	inverter without transformer	-	-	type B ¹⁾	type B ¹⁾
	inverter with transformer	-	-	-	type A
inverter protection class II with switching point/RCMU	inverter without transformer	-	-	-	type B
	inverter with transformer	-	-	-	type A

independently of the supply system (TN, TT) of the low voltage network:

¹⁾ According to VDE V 0126-1-1 (Section 4.7.1), if a transformerless inverter does not contain an RCMU then RCDs with a rated residual current of ≤ 30 mA must be used on the AC side for the purpose of personal protection on the DC side (however, high leakage currents may still occur and must be monitored).

²⁾ For load feeder with sockets (laypersons, outdoor use): $\Delta n \leq 30$ mA or additional residual current operated protective device in the load feeder with $\Delta n \leq 30$ mA (see VDE 0100-410, Section 411.3.3).

Table 1: Use of RCDs in systems where protection cannot be achieved by using overcurrent protective devices to perform an automatic switch-off

Note 1 — Type B+ RCDs can also be used instead of Type B RCDs in Germany

In line with VDE 0100-410 (Section 411.3.3), RCDs should be used as additional protection (where $\Delta n \leq 30$ mA) if outgoing circuits with sockets are present (also applies to final circuits outdoors).

Note 2 — * UK Installations; refer to BS 7671 - 712 and the IET Code of Practice - Grid-connected Solar Photovoltaic Systems.

1.8.4. RCDs in electrical machinery

VDE 0113-1 (EN 60204-1): Safety of machinery – Electrical equipment of machines – Part 1: General requirements

Pursuant to Section 6.3, measures must be taken to achieve fault protection (protection in the event of indirect contact) in machines. If machines are used in TT systems, RCDs must be integrated into the machines as components.

A power supply isolating device must also be installed. The latter must meet the requirements for isolating devices pursuant to IEC 60947-1. These requirements are met inter alia by circuit-breakers pursuant to IEC 60947-2.

The ideal combination of both protective measures can be found in the form of a circuit-breaker with residual current trip (CBR) in line with IEC 60947-2 (Annex B) or a modular residual current device (MRCD) in line with IEC 60947-2 (Annex M). Our CBRs in the DFL 8 series and our MRCDs in the DMRCD series are available in various designs.

If electronic equipment capable of producing smooth DC residual currents in the event of a fault is integrated into the machine (e.g. multi-phase operated frequency converters), any residual current operated protective device that needs to be installed must be of Type B or B+ as stipulated by Section 7.7.

1.8.5. Further applications

VDE 0100 / BS7671 722: Low-voltage electrical installations – Requirements for special installations or locations – Supplies for electric vehicles

When charging electric vehicles, Section 722.531.2 stipulates that every connection point (socket) must be protected by a residual current operated protective device with a rated residual current of ≤ 30 mA, unless the corresponding electric circuit incorporates protective separation as a protective measure. Charging stations with sockets or connectors in line with DIN EN 62196 must include precautionary measures against DC residual currents. Type B RCDs may be used for this purpose. Alternatively, Type A or Type F RCDs may be used in conjunction with a residual direct current monitoring device (RDC-DD) in accordance with IEC 62955.

The DFS 4 EV residual current circuit-breaker features an additional internal function for detecting smooth DC residual currents. Therefore, as an RDC-PD (residual direct current protective device), it meets the requirements of standard IEC 62955 and no other residual current protection devices are required.

Important: The DFSS 4 EV is only for use in EV charging circuits as per VDE 0100 / BS7671 -722.

VDE 0100 Part 723*: Erection of low-voltage installations – Requirements for special installations or locations – Classrooms with experimental equipment

As per Section 723.412.5, AC-DC sensitive Type B RCDs with a rated residual current of 30 mA must be provided for additional protection in electric circuits for experimental equipment in TN or TT systems.

VdS 3501*: Damage prevention guideline: Protection against insulation defects in electrical installations with electronic equipment – RCDs and frequency converters

As per Section 4.4, a Type B+ RCD with a rated residual current of ≤ 300 mA is to be provided for fire protection in facilities at risk of fire. The RCD must reliably detect residual currents over a frequency range of 0 to 20 kHz and have a maximum tripping threshold of 420 mA, which must not be exceeded over the entire frequency range. An even higher protection level can be achieved with AC-DC sensitive RCDs that have a frequency range of at least 100 kHz with a maximum tripping threshold of only 300 mA.

This allows extremely high-frequency residual currents to be reliably detected, e.g. in the wood and paper processing industry, where machines with frequency converters operating at switching frequencies > 20 kHz can also be used.

1.8.6. Additional guidelines requiring Type B RCDs:

- DGUV *Information 203-032 (previously BGI 867):
Emergency generators on construction and installation sites
- VdS 2033*: Damage prevention guideline:
Electrical systems in facilities at risk of fire and risks equivalent to these
- VdS 2046*: Safety regulations
for electrical systems up to 1000 volts
- VdS 2067*: Damage prevention guideline:
Electrical systems in agriculture
* No specific requirements relating to UK Regulations.

1.9. — Distribution of electric circuits*

As per Section 5.3.2.3 of VDE 0160/EN 50178, electric circuits with electronic equipment such as frequency converters must not be connected upstream of any protective devices sensitive to pulsating currents, since (as described above) their function is impaired by smooth DC residual currents (pre-magnetisation of the transformer core).

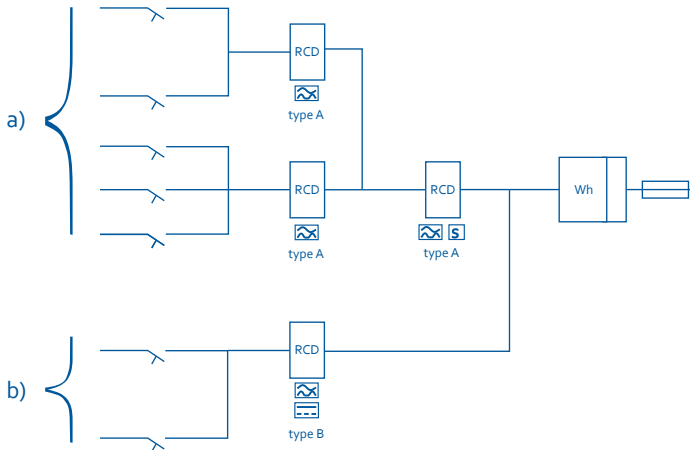

Fig. 10: Distribution of electric circuits in systems with electronic equipment (in accordance with DIN VDE 0160/EN 50178). Segment a) shows electrical circuits in which only AC residual currents and/or pulsating DC residual currents can arise in the event of a fault. Segment b) describes electrical circuits in which smooth DC residual currents can also arise in the event of a fault.

***BS 7671 2018 Amendment 2 does not clearly define this specific safety requirement.**

By default it is a requirement of BS7671 - 531.3.3 e.g.

Type A, F or B cannot be mounted directly down stream of Type AC.

Type B cannot be mounted directly down stream of Type AC, A or F ...

1.10. — Protection via automatic disconnection of the supply

According to Section 531 of VDE 0100-530 / BS7671, RCDs are to be used as protection against electric shock by switching off the power supply automatically. In electrical systems with electronic equipment in which smooth DC residual currents are to be expected the correct Type of RCD (RCCB, RCBO, MRCD or CBR) must be selected based on the type of residual / fault current - see BS7671 Annex A53 Fig. A53.1 See next chapter 1.11 for additional details.

RCMs (*residual current monitors*) in conjunction with a switching device with isolating function are only permitted for fire protection (see BS 7671 - 532) in exceptional cases where RCDs can no longer be used due to a very high operating current > 250A.

RCMs for fire protection is unnecessary below 250A . In industrial settings, MRCDs with a rated residual current of ≤ 30 mA may be used for additional protection (personal protection) Testing requirements for the MRCD combined with CB are given in EN 60947 - 2 Annex M.

RCMs are not permitted for use as a form of protection via automatic power supply switch-off. They are ideal for use together with a residual current operated protective device. Our AC-DC sensitive RCMs in the DRCM series feature a multi-digit display and a pre-alarm. This makes it easy to monitor the residual current. If an adjustable threshold is exceeded, a signal is emitted before the power supply is automatically switched off via the residual current operated protective device if the residual current continues to increase.

1.11. Basic circuits for electronic equipment

The following table shows the time curve for the load and fault currents for electronic equipment with various basic circuits, and also specifies the RCD types suitable for comprehensive protection.

No.	Basic circuit with fault location	Load current profile	Residual current profile	Tripping characteristic				
				AC	A	F	B	B+
1	<p>single-phase without rectification</p>			■	■	■	■	■
2	<p>leading edge control</p>			■	■	■	■	■
3	<p>burst control</p>			■	■	■	■	■
4	<p>single-phase</p>			■	■	■	■	■
5	<p>two-pulse bridge rectifier</p>			■	■	■	■	■
6	<p>half-controlled two-pulse bridge rectifier</p>			■	■	■	■	■
7	<p>frequency converter with two-pulse bridge rectifier</p>					■	■	■

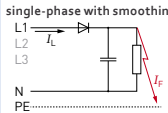
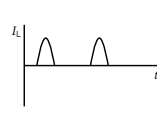
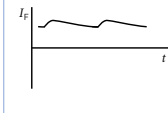
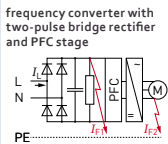
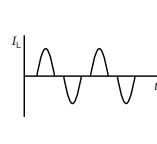
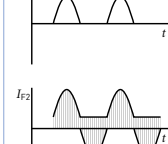
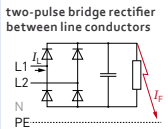
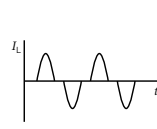
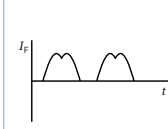
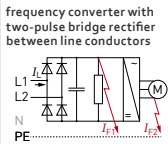
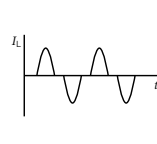
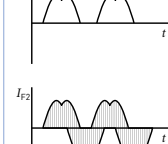
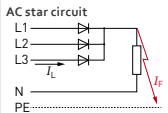
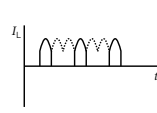
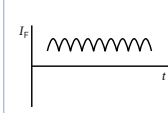
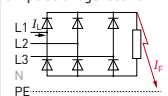
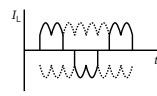
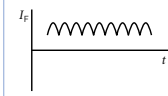
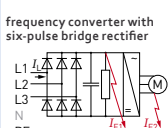
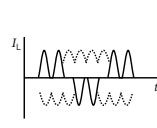
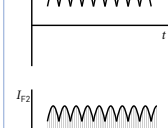
No.	Basic circuit with fault location	Load current profile	Residual current profile	Tripping characteristic				
				AC	A	F	B	B+
8	<p>single-phase with smoothing</p> 						■	■
9	<p>frequency converter with two-pulse bridge rectifier and PFC stage</p> 						■	■
10	<p>two-pulse bridge rectifier between line conductors</p> 						■	■
11	<p>frequency converter with two-pulse bridge rectifier between line conductors</p> 						■	■
12	<p>AC star circuit</p> 						■	■
13	<p>six-pulse bridge rectifier</p> 						■	■
14	<p>frequency converter with six-pulse bridge rectifier</p> 						■	■

1.12. ———— **Generation of a smooth DC residual current from individual currents**

Simplified circuit consisting of a three-phase network with frequency converter B6 bridge connection and insulation fault.

The residual current i_F is calculated by adding together the individual currents i_{L1} , i_{L2} and i_{L3} in the three conductors L1, L2 and L3. The individual conductor currents i_{L1} to i_{L3} represent pulsating DC residual currents with longer zero point contact, resulting from the commutation of three of the six diodes. Their individual magnetic fluxes are combined in the transformer core. The result is a magnetic flux with a high direct component which is proportional to the residual current i_F . This leads to the pre-magnetisation of the transformer core and greatly restricts or even prevents detection of any AC residual currents which may still be present.

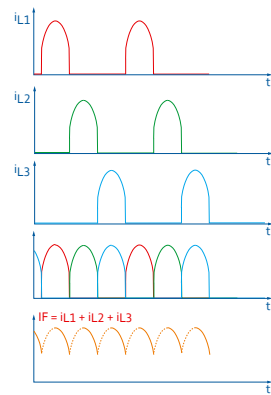
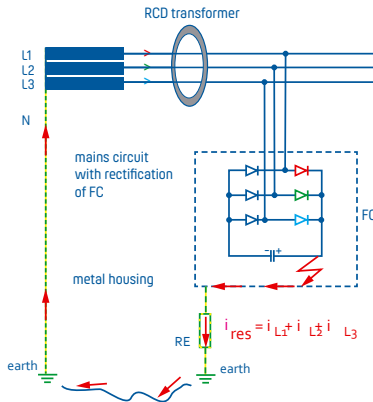

Fig. 11: Impact of an insulation fault on the intermediate circuit capacitor currents with six-pulse bridge rectifier

Fig. 12: Illustration of the individual conductor

Part II

The tripping current
frequency response of
AC-DC sensitive RCDs
and its significance
for the level of protection

2. Tripping current frequency response and level of protection

2.1. ——— Protection by Type A RCDs which are sensitive to pulsating currents

Conventional residual current operated protective devices in line with EN 61008/VDE 0664 Part 10 which are sensitive to pulsating currents are designed for Type A residual currents according to IEC 60755 2017 (*General requirements for residual current operated protective devices*), i.e. they are only intended to respond to AC residual currents and pulsating DC residual currents at their rated frequency, or in other words the mains frequency. The response thresholds for residual currents with different frequencies are not defined. Tripping is therefore not guaranteed by these RCDs for smooth DC residual currents or higher-frequency AC residual currents. Too large a direct component in the residual current can even prevent tripping as a result of the mains-frequency AC residual current. The level of protection achieved by a Type A RCD, as shown in Tab. 1, is determined by its rated residual current at rated frequency.

Rated residual current $I_{\Delta n}$	Level of protection (at rated frequency)		
	Fault protection ¹⁾	Fire protection ²⁾	Additional protection ³⁾
0.03 A	■	■	■
0.1 A	■	■	
0.3 A	■	■	
> 0.5 A	■		

¹⁾ Protection against indirect contact (VDE 0100-410)

¹⁾ UK BS7671 411.3.2

²⁾ Protection against electrical fires

²⁾ UK BS7671 532.2

³⁾ Protection against direct contact, personal protection (VDE 0100-410)

³⁾ UK BS7671 415.11

Table 2: Assignment of achievable level of protection to rated residual current for Type A RCDs

2.2. ——— Protection by Type F RCDs

Type F RCDs meet all requirements for Type A RCDs which are sensitive to pulsating currents and also detect residual currents with mixed frequencies other than 50 Hz. They are intended for use in electrical systems incorporating electronic equipment capable of generating residual currents which contain low-frequency and high-frequency components as well as a high 50 Hz component (e.g. when using

single-phase operated frequency converters). This ensures that tripping is not prevented in response to the 50 Hz component (which is present in the residual current with sufficient amplitude) if the residual current has low-frequency and high-frequency components. This cannot be guaranteed with sufficient certainty for Type A RCDs.

Note — *Type F RCDs are not suitable for the detection of smooth DC residual currents and are, therefore, no substitute for Type B or B+ RCDs.*

Product standard DIN EN (BSEN) 62423 sets out requirements for Type F RCDs. Section 531.3.3 of VDE 0100 / BS7671 contains a list of Type F RCD characteristics . Annex A of DIN VDE 0100-530 provides some example scenarios in which Type F RCDs should be used.

2.3. — **Protection when charging electric vehicles using DFS 4 EV**

Type A RCCBs with the designation DFS 4 A EV and Type F RCCBs with the designation DFS 4 F EV contain an additional function which detects smooth DC residual currents and triggers a switch-off if these DC residual currents exceed a value of 6 mA. These circuit-breakers may only be used for protection when charging electric vehicles according to DIN VDE 0100-722. Type B RCCBs may also be used for this application. They must not be used for any other applications. RCCBs with the designation DFS 4 A EV only detect Type A residual currents (AC and pulsating residual currents at the rated frequency of 50 Hz), as well as smooth DC residual currents (switch-off at max. 6 mA) thanks to the integrated additional function. Residual currents with frequencies \neq 50 Hz are not detected. Only Type B or B+ RCDs may be used in these cases. In addition, the minimum permissible tripping threshold for smooth DC residual currents when Type B or B+ RCDs are used always corresponds to 0.5 times the rated residual current and is therefore significantly greater than 6 mA.

2.4. — **Protection when using the MI design**

AC-DC sensitive residual current circuit-breakers featuring the MI (mobile installation) design and with the designation DFS 4 B SK MI or DFS 4 B+ MI by Doepke are intended for use in mobile distribution boards (e.g. building-site distribution board) in order to maintain the reliable functioning of existing or unknown upstream RCDs.

They meet all the requirements of currently applicable product standards for AC-DC sensitive Type B or B+ residual current circuit breakers, although the following specific points should be noted. The tripping value for smooth DC residual currents is below 6 mA. The laws of physics dictate that the tripping values for pulsating

DC residual currents are also below the lower limit values specified in the product standards. In spite of the lower tripping values for smooth and pulsating DC residual currents, these residual current circuit-breakers demonstrate increased surge current strength and also meet the requirements of ÖVE ÖNORME 8601 (resistance to lightning).

Product standards for Type B or B+ AC-DC sensitive RCDs stipulate that tripping must occur for a smooth DC residual current at between 0.5 and 2 times the value of the rated residual current. If Type B or B+ AC-DC sensitive RCDs are used for additional protection with a rated residual current of 30 mA, tripping in the event of a smooth DC residual current must occur between 15 and 60 mA. However, regardless of its rated residual current, a Type A RCD which is sensitive to pulsating currents must not be subjected to a smooth DC residual current higher than 6 mA. Higher values will result in the magnetic saturation of the summation current transformer, which may lead to its ineffectiveness.

Due to the maximum tripping value of 6 mA for a smooth DC residual current, AC-DC sensitive residual current circuit-breakers featuring the MI design may, however, be connected downstream of Type A or F RCDs which are sensitive to pulsating currents, even though DIN VDE 0100-530 makes no provision for an arrangement of this kind. Undue magnetic saturation of the summation current transformer of upstream Type A or F RCDs cannot occur in this case. This guarantees the protective function of upstream Type A or F RCDs as stipulated by the standards.

Type B or B+ AC-DC sensitive residual current circuit-breakers from Doepke featuring the MI design correspond to the current state of the art. The standards which are currently applicable do not yet take into account their unique tripping characteristic. However, the arrangement of RCDs described above (series connection) represents a solution which complies with the current state of the art in order to meet the requirements of the relevant CE guidelines in terms of conformity evaluations.

2.5. — Implications of the frequency response for the level of protection

In electrical systems with electronic equipment which is not galvanically isolated from the mains, smooth DC residual currents or residual currents with frequencies or mixed frequencies which differ greatly from the mains frequency may occur in the event of an earth fault. In order to achieve residual current protection in systems with equipment of this

kind, a residual current operated protective device is required with a level of AC-DC sensitivity that goes beyond the traditional use of the term 'AC/DC', i.e. one which guarantees broad-range detection of residual currents at all the frequencies which may occur in the system and triggers disconnection if necessary. It is also debatable whether the level of protection dictated by the rated residual current for the rated frequency can also be assumed for the entire remainder of the frequency range detected by the residual current operated protective device. Here, a detailed evaluation is possible with the DRCA 1 residual current analysis software, which observes the tripping behaviour of the RCDs at different frequencies.

2.6. — Protection by Type B RCDs with extended frequency range

Many types of power electronics equipment – such as uninterrupted power supplies, photovoltaic inverters or frequency converters – generate a bipolar square wave voltage (clocked direct voltage) from smooth direct voltages, either internally or directly as an output voltage; this bipolar square wave voltage modulates the sinusoidal output voltage with the desired output frequency as a result of pulse width control. This means, for example, that frequency converters may cause not only residual currents at mains frequency and smooth DC residual currents in the event of a fault, but also residual currents with a frequency mix of the clock frequency with its harmonic components and the output frequency. In order to guarantee comprehensive residual current protection even if such equipment is used, the residual current operated protective device used for this purpose must therefore also trip in response to smooth DC residual currents and AC residual currents at these frequencies.

In practice, this means that RCDs must respond so sensitively to residual currents at all frequencies from 0 Hz up to the highest conceivable clock frequency of the equipment that the desired level of protection is guaranteed not only at the rated frequency, but across the entire frequency range.

This is the only way to avoid miscalculating the scope of protection achievable when selecting a residual current operated protective device on the basis of its rated residual current.

However, power electronics equipment frequently causes high leakage currents, which may also result in the unintended tripping of RCDs. The response threshold frequency of the residual current operated protective device should therefore be only slightly below the limit necessary to achieve the desired level of protection.

RCDs with a response characteristic of B meet these requirements to a greater or lesser extent, depending on the standard according to which they are designed.

2.7. Requirements for the tripping current level

In order to guarantee a uniformly high level of protection across the entire frequency range, the residual operating current of a Type B residual current operated protective device does not necessarily need to be less than or equal to the rated residual current at all frequencies. For instance, it is widely known that RCDs for personal protection have to respond to residual currents with a frequency of 50 Hz at a maximum of 30 mA. However, the permitted response threshold may be significantly higher for a DC residual current or residual currents at higher frequencies, since – from the perspective of potential cardiac injuries – the human body is less sensitive to these currents than to a 50 Hz AC current. Fig. 13 shows how the tripping current frequency response of AC-DC sensitive RCDs can be adjusted to the frequency-dependent current sensitivity of humans in order to achieve the broadest possible protection against faults and additional protection (personal protection) without the residual current operated protective device always responding at a threshold of 30 mA for residual currents at the various frequencies, or in other words with an unnecessary level of sensitivity. Information on the risks posed by currents passing through the human body at frequencies not equal to 50 Hz can be found in Part 2 of IEC 60479 (*Effects of current passing through the human body*) in the form of a hazard curve for frequencies up to 150 kHz. Using frequency as a basis, it specifies current limit values as a multiple of the limit value permissible at 50 Hz, above which the human body may suffer an electric shock resulting in fatal ventricular fibrillation as a result of longitudinal current flow exceeding the duration of a cardiac cycle. Curve (a) in Fig. 13 is an expanded version of the hazard curve on the basis of information from Part 1 of IEC 60479, including frequencies below 50 Hz converted to absolute current values for a probability of occurrence of < 5%.

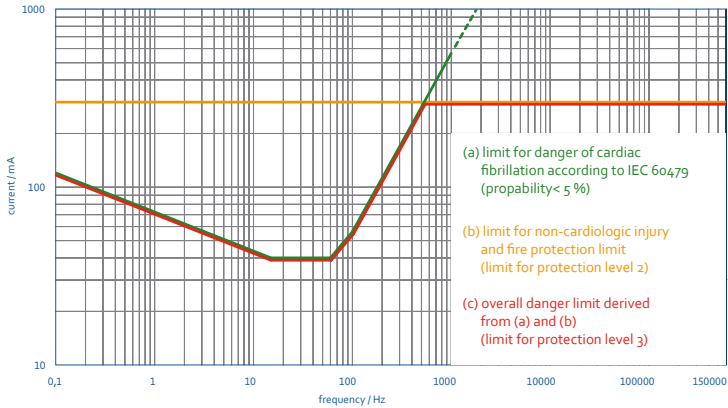

Fig. 13: Hazard limit values for various effects of current passing through the human body

RCDs intended solely to protect humans against this cardiac effect of currents may therefore have a tripping current frequency response with an upper limit that rises sharply upwards as the frequency increases (as shown by curve (a) in Fig. 13). They would therefore have an extremely low sensitivity of response to residual currents at higher frequencies and would therefore be largely immune to undesired tripping by leakage currents at these frequencies.

RCDs of this kind would not, however, provide the human body with adequate protection against other electropathological effects of currents (such as thermal and electrochemical effects at high frequencies), since the current limits acceptable for these effects require lower response values. IEC 60479-1 does not make any direct stipulations concerning the thermal and electrochemical effects of alternating currents. It can, however, be assumed that alternating residual currents up to 150 kHz passing through the human body will not produce effects which exceed those described in Section 4.4 of IEC 60479-1 for direct currents with the same RMS value.

Irreversible damage can therefore be expected even from exposure to high-frequency AC currents at strengths of 0.3 A, even if the exposure only lasts for a matter of minutes. A residual current above this limit must therefore never pass through a human body for an extended period.

Curve (a) in Fig. 13 only falls below this current value in the frequency range up to approx. 500 Hz (hazard curve (b)), i.e. above this frequency the cardiac effect is outweighed by the human body's sensitivity to the thermal and electrochemical effects of the current. A hazard curve which takes account of as many effect mechanisms as possible must therefore not rise arbitrarily in accordance with curve (a) as the frequency increases; instead, it must level out at a constant value when a particular level is reached (maximum 0.3 A) on the basis of the above discussion.

Note — *The current limit of 0.3 A, which was selected as a result of the meagre and inexact information provided in IEC 60479-1, means that complete protection through automatic switch-off cannot be expected in the event of direct contact. In a worst-case scenario, higher-frequency currents below this limit passing through a human body may also render the individual incapable of freely releasing the live conductor. However, given that the permitted current flow duration is relatively long, it is much more likely that the individual will receive external assistance or will manage to release themselves than if they were subjected to the cardiac effect of a 50 Hz current. The value of 0.3 A represents a compromise between a high tripping threshold to avoid nuisance tripping due to leakage currents and the lowest possible threshold for safety reasons. Personal protection (protection against direct contact) may only ever be regarded as additional protection, i.e. as an 'emergency brake' in the event that the basic protection and the fault protection should fail.*

To minimise the risks posed by all three effects of the residual current, the tripping current of AC-DC sensitive RCDs for extensive personal protection must therefore remain below the overall hazard curve (c) across the entire frequency range covered. RCDs with a rated residual current of 0.03 A and a rated frequency of 50 Hz may therefore have tripping thresholds which are higher than the rated frequency of 50 Hz at frequencies above 100 Hz. The frequency-dependent value of 0.3 A should, however, not be exceeded for frequencies of > 600 Hz.

Furthermore, the limit value of 0.3 A for the tripping current of RCDs has long been the upper limit stipulated by experts for protection against fires caused by residual currents. As with Type A RCDs that are sensitive to pulsating currents, highly AC-DC sensitive Type B RCDs, which are suitable for the higher protection level 3, can also be used to achieve the lower protection levels 2 and 1 for residual currents of all frequencies right up to the upper limit frequency (see Table 2). If the tripping current frequency response of a Type B residual current operated protective device meets the above requirements, fire protection is also guaranteed for all the residual current frequencies covered.

2.8. Requirements applicable to the upper frequency limit of residual current detection

The output voltages of power electronics equipment can be clocked with very different frequencies. The frequency spectrum of the potential residual currents is therefore correspondingly wide. A residual current at the output of a three-phase operated frequency converter in a 50 Hz network contains components at several frequencies: the clock frequency and its harmonic components, the motor frequency and the frequency of 150 Hz, which is produced by the six-pulse rectifier as the ripple of the intermediate circuit voltage. The example depicted in Fig. 14 shows the extent to which the various frequency components are contained in the total residual current, depending on the set motor frequency f_{Mot} . The total residual current $I_{\Delta sum}$ is calculated by geometric addition of the residual current components $I_{\Delta Mot}$, $I_{\Delta clock}$ and $I_{\Delta 150 Hz}$, i.e. the partial currents at the motor current frequency, the clock frequency and the ripple frequency of the intermediate circuit direct voltage.

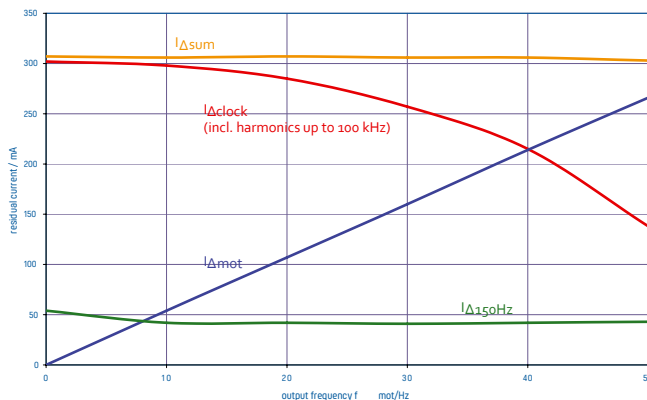

Fig. 14: Residual current components of various frequencies at the output of a three-phase operated frequency converter at a clock frequency of 8 kHz and a fault loop resistance of 780 ohm

Fig. 14 makes it clear that at low motor frequencies (f_{Mot}), the residual current component $I_{\Delta clock}$ at the clock frequency accounts for almost all of the total I_{sum} RMS value of the residual current. Since the clocked output voltage consists of square wave pulses, it contains not only components at the elementary frequency, but also a significant proportion of odd-numbered harmonic components. Popular frequency converters available on the market today can be operated at clock frequencies of up to 16 kHz, meaning that residual currents can also be produced at this square-wave frequency.

The second harmonic component (48 kHz) has an amplitude of up to 30 % of the 16 kHz fundamental component and therefore represents approx. 10 % of the effective value of the total residual current. Even if standard frequency converters are used, the upper limit frequency for residual current tripping should therefore be at least 50 kHz. Converters with higher clock frequencies are also offered for rapidly rotating machines.

Other electronic equipment such as PV inverters, UPS units and switching power supplies are also generally clocked at higher frequencies, meaning that the residual current operated protective device should detect residual current components at frequencies of up to at least 150 kHz in order to provide comprehensive protection.

2.9. ——— Frequency response for a consistent level of protection

Fig. 15 uses the example of a DFS 4 B NK residual current circuit-breaker with a rated residual current of 30 mA in order to show the tripping current frequency responses for RCDs optimised in line with the above requirements. In all frequency ranges, the characteristic curve runs below the total hazard curve (c) from Fig. 13. Based on current understanding, the switch with the rated residual current 30 mA also offers fault protection, fire protection and extensive (although not absolute) personal protection above the frequency of 1000 Hz up to 150 kHz. The tripping current response threshold is always just below the permitted maximum limit for protection level 3. This ensures that undesired tripping as a result of leakage currents in the kHz range are largely avoided at a consistently high protection level of 3. The earth resistance necessary for fault protection must be dimensioned on the basis of the highest tripping current in the frequency range detected, i.e. 0.3 A, rather than the rated residual current. The tripping current frequency response for AC-DC sensitive residual current circuit-breakers in the DFS 4 B NK series is also designed in such a way that the level of protection assigned to the rated residual current in Tab. 1 applies to the entire frequency range over which the residual current is detected. For example, the frequency response of the DFS 4 B NK residual current circuit-breaker (Fig. 15) with a rated residual current of 0.3 A is below 0.3 A throughout the entire range detected. According to Tab. 1, it therefore offers protection level 2 at high residual current frequencies as well as at the rated frequency.

FREQUENCY RESPONSE WITH A 'LEAP IN PROTECTION LEVEL' IN SYSTEMS WITH HIGH LEAKAGE CURRENTS

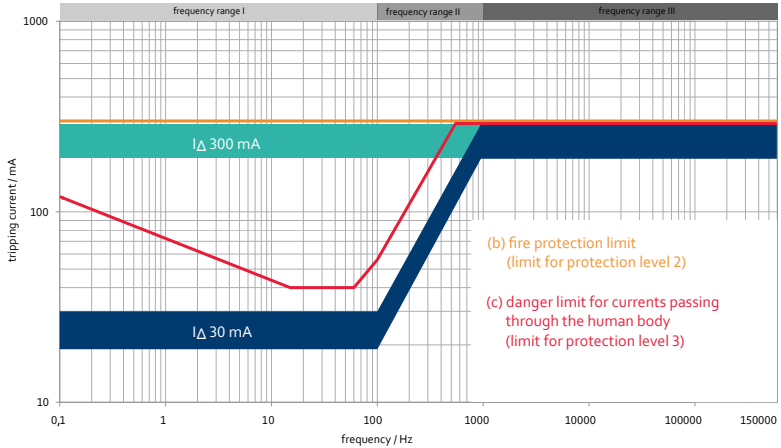

Fig. 15: Tripping current frequency responses for the DFS 4 B NK residual current circuit-breaker in relation to the hazard limits for personal and fire protection

2.10. Frequency response with a 'leap in protection level' in systems with high leakage currents

In systems with several frequency converters and/or long motor supply cables, residual current circuit-breakers which offer a uniform protection level across frequencies may trip accidentally as a result of high leakage currents in frequency band III (Fig. 15). In such cases the tripping current of the residual current operated protective device must be higher in this frequency range, which corresponds to a reduction in the level of protection by one or even two levels. As of a particular frequency, the level of protection therefore jumps to a lower level within the frequency range. Fig. 16 provides a qualitative representation of these frequency responses using the example of various residual current circuit-breakers of type DFS 4 B SK.

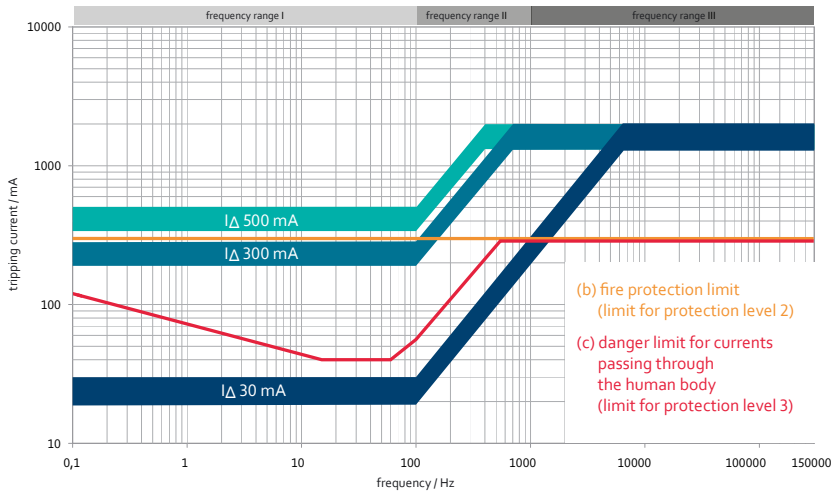

Fig. 16: Frequency responses of the tripping current for the DFS 4 B NK residual current circuit-breaker in relation to the hazard limits for personal and fire protection

The frequency response of the residual current circuit-breaker with a rated residual current of 30 mA is only below the total hazard curve (c) in frequency ranges I and II, thereby offering protection level 3. In range III, however, the response threshold continues to increase in line with frequency, and then levels out at a constantly high value of 3 A until the end of the range detected.

These circuit-breakers are therefore largely protected against undesired tripping as a result of leakage currents at the clock frequency of the electronic equipment. This immunity to high-frequency leakage currents is, however, achieved at the price of a lower level of protection in the higher-frequency range. The level of protection only corresponds to level 3 (i.e. the level expected in line with Tab. 1) in frequency bands I and II. In frequency range III, however, 'only' level 1 can be achieved with this type of circuit-breaker, namely 'protection in the event of indirect contact' (fault protection). A jump in the level of protection, from fire protection to fault protection only, also occurs in the case of RCDs with a rated residual current of 0.3 A as the residual current frequency increases. Fault protection can, however, still be easily achieved for these high frequencies. To this end, the earth resistance is dimensioned for the tripping current, which although high is precisely defined for the remainder of frequency range III.

2.11. Requirements laid down in standards in relation to the tripping current frequency response

The properties and therefore the tripping frequency responses of Type B residual current circuit-breakers are described in international standards IEC 62423 and IEC 60755, in German standard DIN EN 62423 (VDE 0664-40) and in German standard DIN VDE 0664-400 (Type B+ RCCBs). Residual current circuit-breakers/miniature circuit-breakers are also covered by German standard DIN VDE 0664-401 (Type B+ RCBOs): **Note IEC / BSEN 62423 does not recognise the use of B+.**

In some cases, the requirements which apply to tripping frequency responses differ in terms of the maximum permissible tripping thresholds and the highest tripping frequency.

In Germany, standard DIN EN 62423 (VDE 0664-40) on the one hand and standards DIN VDE 0664-400 and DIN VDE 0664-401 on the other hand make a distinction between Type B RCDs and Type B+ RCDs.

Type B RCDs must detect residual currents up to an upper limit frequency of just 1 kHz, with the tripping current being allowed to rise to 14 times the rated residual current at higher frequencies. In contrast, Type B+ devices must trip up to a frequency of 20 kHz, and the tripping current is not allowed to exceed 420 mA at any frequency. This specification also applies to Type B+ RCDs with rated residual currents > 30 mA. This is to achieve an improved level of fire protection¹ compared to Type B RCDs.

Note — *The authorised German draft standards E DIN VDE 0664-100 for Type B RCCBs and E DIN VDE 0664-200 for Type B RCBOs have been replaced by DIN EN 62423 (VDE 0664-40). In addition, preliminary standard DIN VDE V 0664-110 for Type B+ RCCBs has been replaced by standard DIN VDE 0664-400, and preliminary standard DIN VDE V 0664-210 for Type B+ RCBOs has been replaced by standard DIN VDE 0664-401. The content of these standards is identical to that of the preliminary standards.*

Our DFS 4 B NK residual current circuit-breakers comply with all currently applicable standards for AC-DC sensitive residual current circuit-breakers. With an upper limit frequency of 150 kHz at a

¹ *The limit of 420 mA does not correspond to the rated residual current of 300 mA that has been required for fire protection for years, but our experience with Type A RCDs has revealed that they too provide adequate protection against electrical fires. Type A RCDs with a rated residual current of 300 mA are also characterised by a higher response threshold of up to 420 mA for pulsating DC residual currents.*

tripping threshold of < 300 mA, they exceed the requirements of these standards significantly extending the scope of protection. In Germany, we therefore recommend that these RCDs should be used when possible. In the UK the current standard BS7671 accepts Type B RCDs manufactured to BSEN62423 i.e. No defined protection for residual currents >1 kHz. Consequently the Doepke Type BSK offers an improved level of residual current detection for fault currents above 1 kHz < 150 kHz, where the BNK would be too sensitive. Additional safety measures should take account of potentially higher residual currents.

2.12. ——— Earth resistances for fault protection

The earth resistance value (RE) in systems with high frequency residual current must be based on maximum frequency at which residual currents could be generated and the corresponding maximum trip threshold of the RCD e.g. $RE = UB / I\Delta A_{max} @ f_{max}$.

The permissible touch voltages UB can be based on the values known for 50 Hz (50 V or 25 V).

2.13. ——— Summary

As with Type A RCDs, the level of protection provided by AC-DC sensitive RCDs can likewise be identified from their rated residual current. The frequency response of the tripping current must therefore always remain below the hazard limit which applies to the relevant level of protection.

Matching the frequency response characteristic closely to the corresponding limit curves can minimise undesired responses by the RCDs to leakage currents at the various frequencies. In practice, however, high leakage currents frequently require a residual current operated protective device with high response current thresholds in the frequency range of the leakage currents. The level of protection specified for the rated residual current is, however, frequently no longer guaranteed by such a device, since its tripping current is above the hazard limit curve specified for this level of protection at particular frequencies. The current standards for Type B RCDs do not as yet contain any provisions prohibiting such jumps in protection level over the various frequencies. The upper frequency limits of residual current detection specified in these standards are also too low to ensure protection against the residual currents of most clocked electronic equipment. The German standards for Type B+ RCDs dispel certain

ambiguities in respect of fire protection, at least for equipment with residual current frequencies of up to 20 kHz; however, this protective effect is not guaranteed for certain common types of equipment with higher clock frequencies. It is therefore currently impossible for system designers to use the tripping current frequency response of the selected residual current operated protective device to determine whether the required level of protection for the relevant application is in fact achieved for all potential residual current frequencies.

Part III

Appendix

3. Appendix

3.1. ——— Abbreviations used in the text

Abbrevia- tion	Meaning
RCD	Residual current device
RCCB	Residual current operated circuit-breaker
RCBO	Residual current operated circuit breaker with integral overcurrent protection
CBR	Circuit-breaker incorporating residual current protection
MRCD	Modular residual current device
RCM	Residual current monitor
RCMU	Residual current monitoring unit
EMC	Electromagnetic compatibility
FC	Frequency converter
PE	Protective earth
RF	Fault resistance
IF	Residual current
INV	Inverter

Table 3: Overview of abbreviations

3.2. Overview tables for RCDS of Type B SK / B+ / NK

Type B SK	Characteristics	Comment	
two-pole			
DFS 2/4 B SK	RCCB, 230 V, AC-DC sensitive, 16–125 A, 2/4 MW, two-pole	The SK design is suitable for use in electrical systems in which particularly high leakage currents are to be expected in the range of the switching frequencies of the electronic equipment and in which fire protection is not required. The lower sensitivity in the upper frequency range means with extended frequency that undesired tripping is largely avoided. Tripping frequency response in line with BS EN 62423 range up to 150 kHz, higher tripping threshold for frequencies >1 kHz up to 150 kHz compared to DFS 4 B NK. For systems with PV inverters, frequency converters, UPS devices etc.	
FIB B SK FIC B SK	RCBO, 230 V, AC-DC sensitive, 6–32 A, 4 MW, one-pole + N		
four-pole			
DFS 4 B SK DFS 4 B SK S (selective)	RCCB, 230/400 V, AC-DC sensitive, 4 MW, four-pole		
FIB B SK FIC B SK	RCBO, 230/400 V, AC-DC sensitive, 6–32 A, 6 MW, three-pole + N		
DFL 8 B SK	CBR, 230/400 V, AC-DC sensitive, 100–250 A, four-pole, rated residual current 30 mA, mounted on mounting plate or in N7 housing		
	CBR, 230/400 V, AC-DC sensitive, 100–250 A, four-pole, adjustable rated residual current, mounted on mounting plate or in N7 housing		

Table 4: Overview of Type B SK

Type B+	Characteristics	Comment (Germany only)	
two-pole			
DFS 2/4 B+	RCCB, 230 V, AC-DC sensitive, 16–125 A, 2/4 MW, two-pole	For use in electrical systems in which preventive fire protection is required (tripping threshold max. 420 mA). Tripping frequency response in line with DIN VDE 0664-400 up to 20 kHz. For systems with PV inverters, frequency converters, UPS devices etc.	
four-pole			
DFS 4 B+	RCCB, 230 V/400 V, AC-DC sensitive, 16–125 A, 4 MW, four-pole		
DMRCD 1B+	MRCD, AC-DC sensitive, 4 MW, adjustable rated residual current, pre-alarm, 10-way LED display, external summation current transformer		

Table 5: Overview of Type B+

Type B NK	Characteristics	Comment	
two-pole			
DFS 2/4 B NK	RCCB, 230 V, AC-DC sensitive, 16–125 A, 2/4 MW, two-pole	For use in electrical systems that call for preventive fire protection with an extended frequency range of up to 150 kHz (tripping threshold max. 300 mA).	
FIB B NK FIC B NK	RCBO, 230 V, AC-DC sensitive, 6–32 A, 4 MW, one-pole + N		
four-pole			
DFS 4 B NK DFS 4 B NK S (selective)	RCCB, 230/400 V, AC-DC sensitive, 16–125 A, 4 MW, four-pole		
FIB B NK FIC B NK	RCBO, 230/400 V, AC-DC sensitive, 6–32 A, 6 MW, three-pole + N	Tripping frequency response in line with BSEN 62423 (VDE 0664-40) with extended frequency range up to 150 kHz.	
DFL 8 B NK	CBR, 230/400 V, AC-DC sensitive, 100–250 A, four-pole, mounted on mounting plate/in N7 housing		
DFL 8 B NK X	CBR, 230/400 V, AC-DC sensitive, 100–250 A, four-pole, adjustable rated residual current, rated residual current 30 mA, mounted on mounting plate/in N7 housing	For systems with PV inverters, frequency converters, UPS devices etc.	

Table 6: Overview of Type B NK

3.3. RCD tripping limit values

Tripping characteristic	Type AC	Type A	Type F	Type B	Type B+	Tripping threshold
AC residual current	✓	✓	✓	✓	✓	$0.5 \text{ to } 1.0 \times I_{\Delta n}$
Pulsating DC residual currents (positive or negative half-wave)	✗	✓	✓	✓	✓	Phase angle 0° $0.35 \text{ to } 1.4 \times I_{\Delta n}$
	✗	✓	✓	✓	✓	Phase angle 90° $0.25 \text{ to } 1.4 \times I_{\Delta n}$
	✗	✓	✓	✓	✓	Phase angle 135° $0.11 \text{ to } 1.4 \times I_{\Delta n}$
AC residual current with superimposed smooth DC residual current	✗	✓	✓	✓	✓	max. $1.0 \times I_{\Delta n}$ + DC offset
		+6 mA	+10 mA	+0.4 $I_{\Delta n}$	+0.4 $I_{\Delta n}$	

Tripping characteristic	Type AC	Type A	Type F	Type B	Type B+	Tripping threshold
Pulsating DC residual currents with superimposed smooth DC residual current	✗	✔	✔	✔	✔	max. $1.4 \times I_{\Delta n}$ + DC offset
		+6 mA	+10 mA	+0.4 I Δ n	+0.4 I Δ n	
Mixed-frequency residual current	✗	✗	✔	✔	✔	0.5 to 1.4 \times I Δ n
Smooth DC residual current	✗	✗	✗	✔	✔	0.5 to 2.0 \times I Δ n

Table 7:

RCD types with rated residual currents ≥ 30 mA.

In Germany, Type AC residual current operated protective devices are not permitted.

Residual current type	Design	Rated residual current	1 \times I Δ n	2 \times I Δ n	5 \times I Δ n	500 A	
AC residual current	general	< 0.03 A	0.3 s	0.15 s	0.04 s	0.04 s	max. switch-off time
		0.03 A	0.3 s	0.15 s	0.04 s	0.04 s	
	> 0.03 A	0.3 s	0.15 s	0.04 s	0.04 s		
	selective	> 0.03 A	0.5 s	0.2 s	0.15 s	0.15 s	
		0.13 s	0.06 s	0.05 s	0.04 s	min. non-tripping time	

When multiplied by a factor of 1.4, these values also apply to pulsating DC residual currents and to residual currents with mixed frequencies.

Residual current type	Design	Rated residual current	2 \times I Δ n	4 \times I Δ n	10 \times I Δ n	500 A	
Smooth DC residual current	general	any value	0.3 s	0.15 s	0.04 s	0.04 s	max. switch-off time
	selective	> 0.03 A	0.5 s	0.20 s	0.15 s	0.15 s	
			0.13 s	0.06 s	0.05 s	0.05 s	min. non-tripping time

Table 8:

Switch-off times and non-tripping times for RCCBs

3.4. Index

A	
AC-DC sensitive	6, 38, 51, 52
AC residual current	7, 36
Additional protection	36
Anti-interference measures	7
B	
Bridge connection	6
B6	6, 12
C	
CBR	27, 30, 50
D	
DC residual current	
smooth	6, 9
DFL8	30
DFL 8 B NK	52
DFL 8 B NK X	52
DFL 8 B SK	51
DFL 8 B SK X	51
DFS 4 B NK	51, 52
DFS 4 B NK S	52
DFS 4 B SK	51
DFS 4 B SK S	51
DMRCD	27, 30
DMRCD 1B+	51
DRCA 1	20
DRCM	30
E	
Effect of dirt	7
Effect of moisture	7, 8
Electronic equipment	6, 44
EMC	7, 11, 50
filter	13, 18, 20
Equipment	
electronic	6, 44
F	
Fault protection	25, 27, 42
FC	50
FIB B NK	52
FIC B NK	52
Fire protection	42, 44, 45, 46, 47, 52
Frequency converter	6, 9, 11, 12, 13, 14, 15, 16, 17, 18, 19, 20, 21, 28, 39, 43, 50
H	
Harmonic component	9, 11, 13, 16, 43, 44
I	
IF	50
Insulation fault	7, 8
Intermediate circuit capacitor	8
Inverter	6, 14, 39, 44
L	
Leakage currents	7, 8, 12, 13, 14, 15, 16, 17, 18, 19, 20, 39, 41, 44, 45, 46, 48, 51
stationary	12
transient	14
variable	13
M	
Mains frequency	8, 36, 38, 39
Mains voltage	
distortions in	12
Motor supply cable	
long	13, 20
MRCD	27, 30, 50
O	
Output frequency	9, 39, 43
Output voltage	11, 16, 39, 43

- P**
- PE ————— 50
 - Personal protection ——— 36, 40, 42, 44
 - Protection level —————
 - 35, 36, 38, 39, 40, 42, 44, 45, 46, 48, 49
- R**
- Rated residual current —————
 - 28, 36, 39, 40, 42, 44, 46, 47, 48
 - RCBO ————— 30, 47, 50
 - RCCB ————— 30, 47, 50
 - RCD ——— 6, 28, 31, 35, 39, 40, 41, 42, 48, 50
 - RCM ————— 30, 50
 - RCMU ————— 50
 - Residual current ————— 7,
 - 8, 9, 15, 28, 33, 36, 38, 39, 40, 41, 43, 47
 - Residual currents ————— 7
 - Resonance frequency ————— 13, 18, 19
 - RF ————— 50
- S**
- Six-pulse bridge rectification ——— 9, 43
 - Standards and guidelines
 - BGI 867 ————— 28
 - BGI 5087 ————— 28
 - DIN VDE 0100-530 / BS7671 531 — 15
 - VDE 0100-530 / BS7671 531 ——— 30
 - VDE 0100 / BS7671 Part 712 ——— 24
 - VDE 0100 / BS7671 Part 722 ——— 27
 - VDE 0100 Part 723 ————— 28
 - VDE 0113-1 ————— 27
 - VDE 0113-1 (EN 60204-1) ——— 27
 - VDE 0160 / EN 50178 ————— 22
 - VdS 2033 ————— 28
 - VdS 2046 ————— 28
 - VdS 2067 ————— 28
 - VdS 3501 ————— 28
 - Switching frequency ——— 9, 13, 15, 18, 21
- T**
- Total current ————— 12
 - Type A ————— 36, 47, 48
 - Type AC ————— 6
 - Type B ——— 39, 40, 42, 47, 48, 51, 52, 53
 - DFL 8 B ————— 14, 51, 52
 - DFS 4 B ——— 14, 44, 45, 46, 51, 52
- V**
- VDE guidelines ————— 22, 27

Doepke

Doepke Schaltgeräte GmbH

e———— info@doepke.de

T———— +49 (0) 49 31 18 06-0

F———— +49 (0) 49 31 18 06-101

www — doepke.de

Doepke UK Ltd

@----- sales@doepke.co.uk

T----- 01628 828 133

www — doepke.co.uk